

JORDAN BAY MARINA

1328 ROOSEVELT TRAIL
RAYMOND, ME

APPLICANT:

PORT HARBOR MARINE
1 SPRING POINT DRIVE
SOUTH PORTLAND, ME 04106

**ENGINEER/SURVEYOR/
LANDSCAPE ARCHITECT:**

SEBAGO
TECHNICS
WWW.SEBAGOTECHNICS.COM
75 John Roberts Rd.
Suite 4A
South Portland, ME 04106
Tel. 207-200-2100

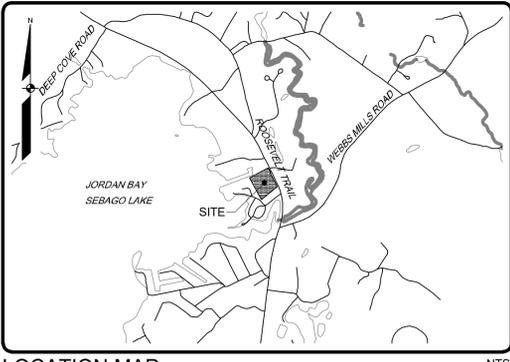
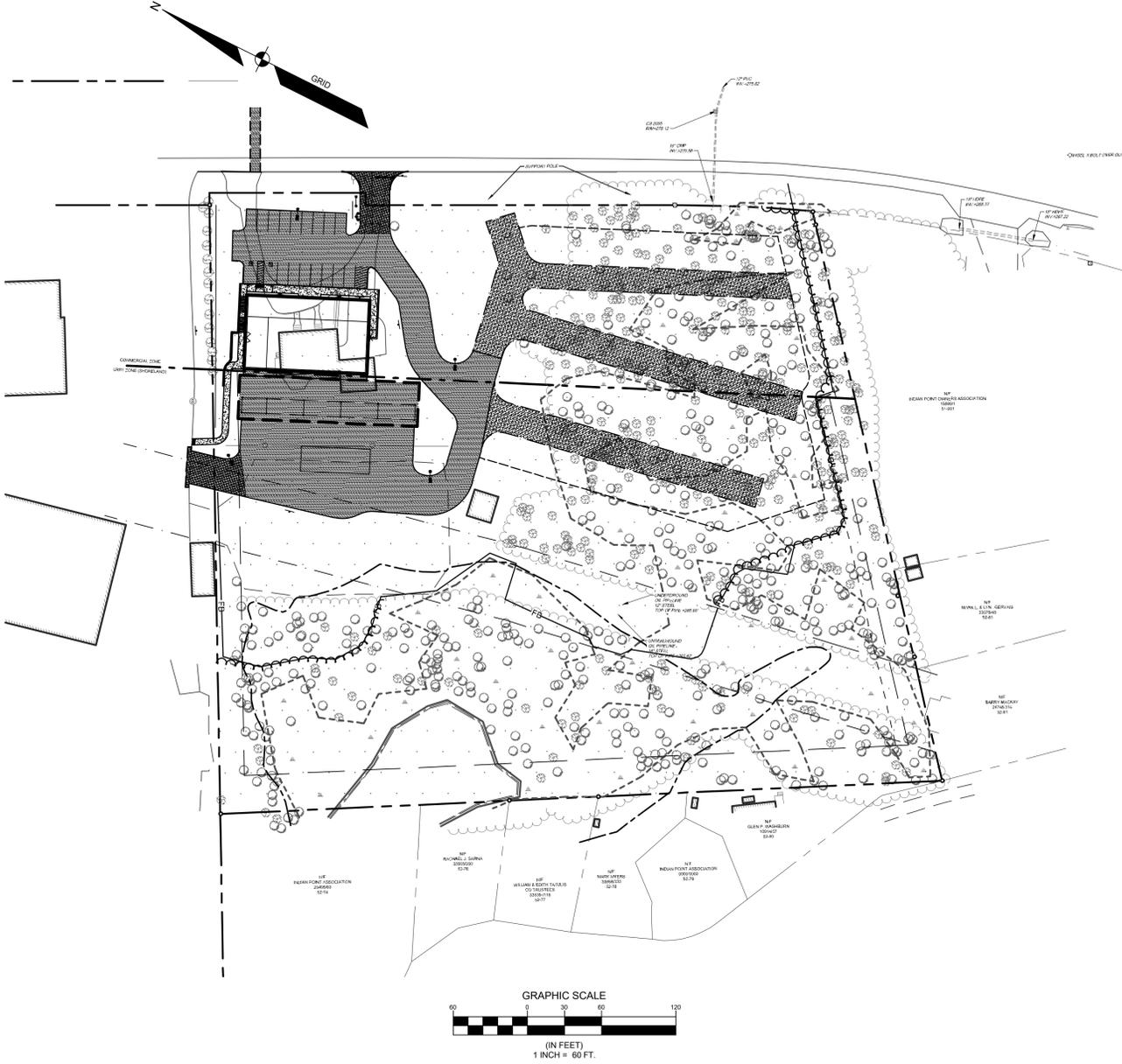

Sheet List Table

Sheet Number	Sheet Title
1	COVER SHEET
2	NOTES & LEGENDS
3	EXISTING CONDITIONS PLAN
4	DEMOLITION & EROSION CONTROL PLAN
5	SITE PLAN
6	GRADING & UTILITIES PLAN
7	LANDSCAPE PLAN
8	EROSION CONTROL NOTES
9	DETAILS
10	DETAILS
11	DETAILS
12	DETAILS
13	DETAILS
1 of 2	EXISTING CONDITIONS - SWP
2 of 2	PROPOSED CONDITIONS - SWP



C	MWE	9/14/22	REVISED PER TOWN OF RAYMOND COMMENTS
B	MWE	7/12/21	REVISED PER REVIEW COMMENTS
A	MWE	6/29/21	RELEASED FOR CLIENT REVIEW
REV	BY	DATE	STATUS

THIS PLAN SHALL NOT BE MODIFIED WITHOUT WRITTEN PERMISSION FROM SEBAGO TECHNICS, INC. ANY ALTERATIONS, AUTHORIZED OR OTHERWISE, SHALL BE AT THE USER'S SOLE RISK AND WITHOUT LIABILITY TO SEBAGO TECHNICS, INC.



COVER SHEET
OF:
JORDAN BAY MARINA
1328 ROOSEVELT TRAIL
RAYMOND, ME
FOR:
PORT HARBOR MARINE
1 SPRING POINT DRIVE
SOUTH PORTLAND, ME 04106

DESIGNED	JSH
DRAWN	DAB
CHECKED	RAM
DATE	06/22/22
SCALE	1" = 60'
PROJECT	14265-02

LEGEND

Table with columns for EXISTING and PROPOSED symbols and descriptions for various site features like property lines, setbacks, utilities, and erosion control.

GENERAL NOTES

- 1. THE RECORD OWNER OF THE PARCEL IS PORT HARBOR MARINE BY THE FOLLOWING DEEDS RECORDED AT THE CUMBERLAND COUNTY REGISTRY OF DEEDS. MAP 51, LOT 2 - DATED DECEMBER 18, 2020 IN BOOK 37597, PAGE 223.
2. THE PROPERTY IS SHOWN AS LOT 2 ON TAX MAP 51 AND IS LOCATED IN THE COMMERCIAL DISTRICT, AND LIMITED RESIDENTIAL/RECREATIONAL (LRR1, SHORELAND) DISTRICT.
3. SPACE AND BULK CRITERIA FOR THE COMMERCIAL ZONE (C) DISTRICT ARE AS FOLLOWS:
C DISTRICT
REQUIRED PROPOSED
MINIMUM LOT SIZE: N/A N/A
MINIMUM FRONT SETBACK: N/A N/A
MINIMUM SIDE SETBACK: N/A N/A
MINIMUM REAR SETBACK: N/A N/A
MAXIMUM BUILDING HEIGHT: 2.5 STORIES 1.5 STORIES
* SEE ORDINANCE FOR MORE SPECIFIC INFORMATION AND CONFIRM WITH A TOWN OFFICIAL.
LRR1 DISTRICT
REQUIRED PROPOSED
MINIMUM LOT SIZE: 2 ACRES 5.9 ACRES
MINIMUM FRONT SETBACK: 20 FEET 82 FEET
MINIMUM SIDE SETBACK: 20 FEET 20+ FEET
MINIMUM REAR SETBACK: 30 FEET 204 FEET
MAXIMUM BUILDING HEIGHT: 35 FEET <35 FEET
* SEE ORDINANCE FOR MORE SPECIFIC INFORMATION AND CONFIRM WITH A TOWN OFFICIAL.
4. NATURAL RESOURCE INVENTORY
5. BOUNDARY AND TOPOGRAPHIC INFORMATION SHOWN HEREON IS BASED UPON FIELD WORK PERFORMED BY SEBAGO TECHNIQS, INC. IN APRIL OF 2021.
6. PLAN REFERENCE:
A. "INDIAN POINT CAMPING AREA AMENDMENT TO ADDENDUM TO FINAL PLAN" PREPARED BY SKINNER & LAMBE, INC DATED MARCH 11, 1988 AND RECORDED IN PLAN BOOK 170, PAGE 70 (CCRD).
B. "MAINE STATE HIGHWAY COMMISSION RIGHT OF WAY MAP STATE HIGHWAY *14 FEDERAL STATE AID PROJECT F-014-1 (5) SHEETS 3-8", RECORDED IN PLAN BOOK 49 PAGE 24-25 (CCRD).
7. ALL WORK SHALL CONFORM TO THE APPLICABLE CODES AND ORDINANCES.
8. CONTRACTOR SHALL VISIT THE SITE AND FAMILIARIZE HIM OR HERSELF WITH ALL CONDITIONS AFFECTING THE PROPOSED WORK AND SHALL MAKE PROVISIONS AS TO THE COST THEREOF. CONTRACTOR SHALL BE RESPONSIBLE FOR FAMILIARIZING HIM OR HERSELF WITH ALL CONTRACT DOCUMENTS, FIELD CONDITIONS AND DIMENSIONS AND CONFIRMING THAT THE WORK MAY BE ACCOMPLISHED AS SHOWN PRIOR TO PROCEEDING WITH CONSTRUCTION. ANY DISCREPANCIES SHALL BE BROUGHT TO THE ATTENTION OF THE ENGINEER PRIOR TO THE COMMENCEMENT OF WORK.
9. CONTRACTOR SHALL NOTIFY ENGINEER OF ALL PRODUCTS OR ITEMS NOTED AS "EXISTING" WHICH ARE NOT FOUND IN THE FIELD.
10. PROVIDE ALL EQUIPMENT AND MATERIALS IN ACCORDANCE WITH MANUFACTURER'S RECOMMENDATIONS AND OWNER'S REQUIREMENTS UNLESS SPECIFICALLY OTHERWISE INDICATED OR WHERE LOCAL CODES OR REGULATIONS TAKE PRECEDENCE.
11. CONTRACTOR SHALL VERIFY ALL DIMENSIONS AND CONDITIONS IN THE FIELD PRIOR TO FABRICATION AND ERECTION OF ANY MATERIAL. ANY UNUSUAL CONDITIONS SHALL BE REPORTED TO THE ATTENTION OF THE ENGINEER.
12. CONTRACTOR SHALL CLEAN AND REMOVE DEBRIS AND SEDIMENT DEPOSITED ON PUBLIC STREETS, SIDEWALKS, ADJACENT AREAS, OR OTHER PUBLIC WAYS DUE TO CONSTRUCTION.
13. CONTRACTOR SHALL INCORPORATE PROVISIONS AS NECESSARY IN CONSTRUCTION TO PROTECT EXISTING STRUCTURES, PHYSICAL FEATURES, AND MAINTAIN SITE STABILITY DURING CONSTRUCTION. CONTRACTOR SHALL RESTORE ALL AREAS TO ORIGINAL CONDITION AND AS DIRECTED BY DESIGN DRAWINGS.
14. SITE CONTRACTOR SHALL OBTAIN ALL REQUIRED PERMITS PRIOR TO CONSTRUCTION.
15. ALL EROSION AND SEDIMENT CONTROL MEASURES SHALL BE INSTALLED IN ACCORDANCE WITH "MAINE EROSION AND SEDIMENT CONTROL BMPs" PUBLISHED BY THE BUREAU OF LAND AND WATER QUALITY OF THE MAINE DEPARTMENT OF ENVIRONMENTAL PROTECTION, LATEST EDITION. IT SHALL BE THE RESPONSIBILITY OF THE CONTRACTOR TO POSSESS A COPY OF THE EROSION CONTROL PLAN AT ALL TIMES.
16. THE CONTRACTOR IS HEREBY CAUTIONED THAT ALL SITE FEATURES SHOWN HEREON ARE BASED ON FIELD OBSERVATION AND BY INFORMATION PROVIDED BY UTILITY COMPANIES. THE INFORMATION IS NOT TO BE RELIED ON AS BEING EXACT OR COMPLETE. THE CONTRACTOR SHALL CONTACT DIG SAFE (811) AT LEAST THREE (3) BUT NOT MORE THAN THIRTY (30) DAYS PRIOR TO COMMENCEMENT OF EXCAVATION OR DEMOLITION TO VERIFY HORIZONTAL AND VERTICAL LOCATION OF ALL UTILITIES.
17. CONTRACTOR SHALL BE AWARE THAT DIG SAFE ONLY NOTIFIES ITS "MEMBER" UTILITIES ABOUT THE DIG. WHEN NOTIFIED, DIG SAFE WILL ADVISE CONTRACTOR OF MEMBER UTILITIES IN THE AREA. CONTRACTOR IS RESPONSIBLE FOR IDENTIFYING AND CONTACTING NON-MEMBER UTILITIES DIRECTLY. NON-MEMBER UTILITIES MAY INCLUDE TOWN OR CITY WATER AND SEWER DISTRICTS AND SMALL LOCAL UTILITIES, AS WELL AS USG PUBLIC WORKS SYSTEMS.
18. CONTRACTORS SHALL BE RESPONSIBLE FOR COMPLIANCE WITH THE REQUIREMENTS OF 23 MRSA 3360-A. IT SHALL BE THE RESPONSIBILITY OF THE CONTRACTOR TO RELOCATION OF ANY EXISTING UTILITIES WHICH CONFLICT WITH THE PROPOSED IMPROVEMENTS SHOWN ON THESE PLANS. IF A UTILITY CONFLICT ARISES, THE CONTRACTOR SHALL IMMEDIATELY NOTIFY THE OWNER, THE MUNICIPALITY AND APPROPRIATE UTILITY COMPANY PRIOR TO PROCEEDING WITH ANY RELOCATION.
19. ALL PAVEMENT MARKINGS AND DIRECTIONAL SIGNAGE SHOWN ON THE PLAN SHALL CONFORM TO THE MANUAL OF UNIFORM TRAFFIC CONTROL DEVICES (MUTCD) STANDARDS.
20. ALL PAVEMENT JOINTS SHALL BE SAWCUT PRIOR TO PAVING TO PROVIDE A DURABLE AND UNIFORM JOINT.
21. NO HOLES, TRENCHES OR STRUCTURES SHALL BE LEFT OPEN OVERNIGHT IN ANY EXCAVATION ACCESSIBLE TO THE PUBLIC OR IN PUBLIC RIGHTS-OF-WAY.
22. IMMEDIATELY UPON COMPLETION OF CUTS/FILLS, THE CONTRACTOR SHALL STABILIZE DISTURBED AREAS IN ACCORDANCE WITH EROSION CONTROL NOTES AND AS SPECIFIED ON PLANS.
23. THE CONTRACTOR SHALL BE FULLY AND SOLELY RESPONSIBLE FOR THE REMOVAL, REPLACEMENT AND RECTIFICATION OF ALL DAMAGED AND DEFECTIVE MATERIAL AND WORKMANSHIP IN CONNECTION WITH THE CONTRACT WORK. THE CONTRACTOR SHALL REPLACE OR REPAIR AS DIRECTED BY THE OWNER ALL SUCH DAMAGED OR DEFECTIVE MATERIALS WHICH APPEAR WITHIN A PERIOD OF ONE YEAR FROM THE DATE OF SUBSTANTIAL COMPLETION.
24. ALL WORK PERFORMED BY THE GENERAL CONTRACTOR AND/OR TRADE SUBCONTRACTOR SHALL CONFORM TO THE REQUIREMENTS OF LOCAL, STATE OR FEDERAL LAWS, AS WELL AS ANY OTHER GOVERNING REQUIREMENTS, WHETHER OR NOT SPECIFIED ON THE DRAWINGS.
25. WHERE THE TERMS "APPROVED EQUAL", "OTHER APPROVED", "EQUAL TO", "ACCEPTABLE" OR OTHER GENERAL QUALIFYING TERMS ARE USED IN THESE NOTES, IT SHALL BE UNDERSTOOD THAT REFERENCE IS MADE TO THE RULING AND JUDGEMENT OF SEBAGO TECHNIQS, INC.
26. THE GENERAL CONTRACTOR SHALL PROVIDE ALL NECESSARY PROTECTION FOR THE WORK UNTIL TURNED OVER TO THE OWNER.
27. THE GENERAL CONTRACTOR SHALL MAINTAIN A CURRENT AND COMPLETE SET OF CONSTRUCTION DRAWINGS ON SITE DURING ALL PHASES OF CONSTRUCTION FOR USE OF ALL TRADES.
28. THE CONTRACTOR SHALL TAKE FULL RESPONSIBILITY FOR ANY CHANGES AND DEVIATION OF APPROVED PLANS NOT AUTHORIZED BY THE ARCHITECT/ENGINEER AND/OR CLIENT/OWNER.
29. DETAILS ARE INTENDED TO SHOW END RESULT OF DESIGN. ANY MODIFICATION TO SUIT FIELD DIMENSION AND CONDITION SHALL BE SUBMITTED TO THE ENGINEER FOR REVIEW AND APPROVAL PRIOR TO ANY WORK.
30. BEFORE THE FINAL ACCEPTANCE OF THE PROJECT, THE CONTRACTOR SHALL REMOVE ALL EQUIPMENT AND MATERIALS, REPAIR OR REPLACE PRIVATE OR PUBLIC PROPERTY WHICH MAY HAVE BEEN DAMAGED OR DESTROYED DURING CONSTRUCTION, CLEAN THE AREAS WITHIN AND ADJACENT TO THE PROJECT WHICH HAVE BEEN OBSTRUCTED BY HIS/HER OPERATIONS, AND LEAVE THE PROJECT AREA NEAT AND PRESENTABLE.
31. ALL GRAVITY CONDUIT PIPES SHALL BE INSTALLED USING A PIPE LASER AND TARGET SYSTEM THROUGH THE PIPE. ON PIPE RUNS 50 FEET OR LESS, THE CONTRACTOR SHALL REQUEST ENGINEER'S APPROVAL TO USE A GROUND LASER.
32. SIDESLOPES SHALL NOT BE STEEPER THAN 3:1 (H:V) EXCEPT AS OTHERWISE IDENTIFIED ON THIS PLAN. ALL SIDESLOPES STEEPER THAN 3:1 (H:V) SHALL BE LINED WITH EROSION CONTROL BLANKET.

UTILITY DEMOLITION NOTES

- 1. PROTECT EXISTING BOUNDARY LINE MONUMENTATION. IF DISTURBED, EXISTING MONUMENTATION TO BE RESET BY A PROFESSIONAL LAND SURVEYOR.
2. DEMOLITION OF UTILITIES REQUIRING TREE REMOVAL SHALL BE COORDINATED WITH THE OWNER AND IN ACCORDANCE WITH PROJECT PLANS.
3. UTILITY DEMOLITION SHALL BE COMPLETED IN COORDINATION WITH NEW INFRASTRUCTURE. CONTRACTOR SHALL ENSURE EXISTING SURFACE DRAINAGE IS MAINTAINED DURING CONSTRUCTION.
4. EXISTING SEWER AND STORM DRAINAGE INFRASTRUCTURE TO REMAIN ACTIVE DURING CONSTRUCTION AND UPON COMPLETION OF PROJECT. DEMOLITION/CONSTRUCTION ACTIVITIES SHALL NOT INTERFERE OR IMPEDE EXISTING FLOWS. CONTRACTOR SHALL PROVIDE BYPASS PUMPING AS REQUIRED DURING SEWER AND STORM DEMOLITION AND NEW CONSTRUCTION. DAMAGE TO EXISTING SEWER INFRASTRUCTURE SHALL BE REPAIRED BY CONTRACTOR AT THEIR EXPENSE.
5. PROTECT EXISTING UTILITIES NOT CALLED OUT TO BE REMOVED DURING CONSTRUCTION.
6. DEMOLITION SHOWN IS FOR MAJOR SITE ELEMENTS TO BE DEMOLISHED. OTHER MINOR DEMOLITION MAY BE REQUIRED AS PART OF CONSTRUCTION AND SHALL BE CONSIDERED INCIDENTAL TO THE COST OF CONSTRUCTION. COORDINATE ALL DEMOLITION WORK WITH SITE AND BUILDING DRAWINGS.
7. PRIOR TO ANY DEMOLITION, THE CONTRACTOR SHALL SUBMIT A SEQUENCE OF DEMOLITION PLANS TO THE OWNER. THIS PLAN SHALL DEPICT LOCATIONS OF PROPOSED TERMINATIONS AND ANY TEMPORARY SERVICES THAT WILL BE NEEDED.
8. CONTRACTOR REQUIRED TO CONFIRM/MAINTAIN BENCHMARKS. IF IMPACTED CONTRACTOR IS RESPONSIBLE FOR NOTIFICATION/RELOCATION AND COORDINATION WITH PROJECT TEAM.

GRADING & EROSION NOTES

- 1. SIDESLOPES SHALL NOT BE STEEPER THAN 3:1 (H:V) EXCEPT AS OTHERWISE IDENTIFIED ON THIS PLAN. ALL SIDESLOPES STEEPER THAN 3:1 (H:V) SHALL BE LINED WITH EROSION CONTROL BLANKET, OR ADDITIONAL MEASURES AS INDICATED.
2. ALL SEDIMENT AND EROSION CONTROL MEASURES SHALL BE INSTALLED IN ACCORDANCE WITH "MAINE EROSION AND SEDIMENT CONTROL BMPs" MANUAL PUBLISHED BY BUREAU OF LAND AND WATER QUALITY MAINE DEPARTMENT OF ENVIRONMENTAL PROTECTION, LATEST EDITION. IT SHALL BE THE RESPONSIBILITY OF THE CONTRACTOR TO POSSESS A COPY OF THE EROSION CONTROL PLAN AT ALL TIMES.
3. ALL AREAS DISTURBED DURING CONSTRUCTION AND NOT RESTORED WITH IMPERVIOUS SURFACES (BUILDINGS, PAVEMENTS, WALKS, ETC.) SHALL RECEIVE LOAM AND SEED PER DETAIL.
4. SEE UTILITY DRAWINGS FOR PIPE AND STRUCTURE DATA TABLES.

CONSTRUCTION PLAN

- 1. PROVIDE EROSION CONTROL MEASURES PRIOR TO SITE DISTURBANCE.
2. WETLANDS, ASSOCIATED SETBACKS AND STREAM SETBACKS TO BE STAKED BY OWNER PRIOR TO SITE DISTURBANCE.
3. BEFORE TREE CLEARING, REFER TO PLANS FOR WOODED BUFFER LOCATIONS. TREES SHALL NOT BE CLEARED WITHIN DESIGNATED WOODED BUFFER AREAS.
4. GRADING AND CLEARING LIMITS SHALL NOT ENCROACH ON ADJACENT PROPERTIES UNLESS NOTED OTHERWISE ON THE PLANS.
5. OPEN AREAS SHALL BE LIMITED TO AREAS BEING WORKED IN. THE AREA STRIPPED OF EXISTING VEGETATION AT ANY GIVEN TIME SHALL BE MINIMIZED AND BE PHASED WHERE PRACTICAL SO THAT AREAS ARE REVEGETATED AND PERMANENTLY STABILIZED BEFORE ADDITIONAL AREAS ARE STRIPPED OF EXISTING VEGETATION. STABILIZE CONSTRUCTION AREAS BY USE OF RIPRAP, SEED, MULCH, OR OTHER GROUND COVER WITHIN ONE WEEK FROM THE TIME IT WAS ACTIVELY WORKED. SURFACES SHALL BE STABILIZED PRIOR TO DIRECTING STORMWATER RUNOFF TOWARD STORMWATER BMPs. PLEASE REFER TO DRAINAGE PLANS FOR WATERSHED AREAS.

UTILITY NOTES

- 1. UTILITY INFORMATION DEPICTED HEREON IS COMPILED USING PHYSICAL EVIDENCE LOCATED IN THE FIELD. UTILITIES DEPICTED HEREON MAY NOT NECESSARILY REPRESENT ALL EXISTING UTILITIES. CONTRACTORS AND/OR DESIGNERS NEED TO CONTACT DIG-SAFE SYSTEMS, INC. (1-888-DIG-SAFE) AND FIELD VERIFY EXISTING UTILITIES PRIOR TO CONSTRUCTION AND/OR EXCAVATION. PROTECT EXISTING ON-SITE SEWER PIPE AND ADJUST MANHOLE RIMS TO GRADE WHERE APPLICABLE.
2. ALL GRAVITY CONDUIT PIPES SHALL BE INSTALLED USING A PIPE LASER AND TARGET SYSTEM THROUGH THE PIPE. ON PIPE RUNS 50 FEET OR LESS, THE CONTRACTOR SHALL REQUEST ENGINEER'S APPROVAL TO USE OR NOT USE A GROUND LASER.
3. MAINTAIN MINIMUM 5'-6" OF COVER ABOVE TOP OF WATER SERVICE PIPE.
4. MAINTAIN MINIMUM 10 FEET HORIZONTAL SEPARATION BETWEEN WATER SERVICES AND OTHER UTILITIES. MAINTAIN MINIMUM 18 INCHES VERTICAL SEPARATION BETWEEN WATER SERVICES AND OTHER UTILITIES.
5. LOWER OR RAISE WATER SERVICES AS REQUIRED TO MAINTAIN MINIMUM 12 INCH VERTICAL SEPARATION FROM OTHER UTILITIES. WATER SERVICES CROSSING SEWERS SHALL MAINTAIN 12 INCH MINIMUM SEPARATION BETWEEN THE BOTTOM OF WATER LINE AND TOP OF SEWER UNLESS NOTED OTHERWISE ON THE PLANS.
6. PIPE:
• SEWER PIPE SHALL BE SDR 35 PVC OR APPROVED EQUAL.
• FORCEMAIN PIPE SHALL BE DR-11 HDPE OR APPROVED EQUAL.
• STORM DRAIN SHALL BE ADS N-12 DUAL WALL HDPE PIPE WITH SMOOTH-WALLED INTERIOR OR APPROVED EQUAL UNLESS NOTED OTHERWISE ON THE UTILITY PLANS.
• WATER PIPE AND FITTINGS SHALL CONFORM TO PORTLAND WATER DISTRICT WATER PIPING SPECIFICATIONS. MAIN WATER SERVICE PIPE SHALL BE DUCTILE IRON, CLASS 52 PUSH-ON PIPE MEETING THE REQUIREMENTS OF AWWA/CANSI C-111/A21.11 (LATEST REVISION). PIPE SHALL BE CEMENT-LINED AWWA/CANSI C-100/A21.4 WITH LINING TWICE THE THICKNESS SPECIFIED, AND COATED TWICE WITH A BITUMINOUS SEAL COATING. PROVIDE THRUST BLOCKS AT ALL WATER SERVICE BENDS.
7. COORDINATE FOUNDATION UNDERDRAIN LOCATIONS WITH ARCHITECTURAL AND STRUCTURAL DRAWINGS.
8. COORDINATE GREASE INTERCEPTOR LOCATIONS WITH ARCHITECTURAL & PLUMBING DRAWINGS.
9. COORDINATE UTILITY INVERTS AT BUILDING WITH ARCHITECTURAL, STRUCTURAL AND PLUMBING DRAWINGS.
10. COORDINATE LOCATION OF SEWER, WATER, GAS, FOUNDATION DRAINS AND ROOF DRAIN INVERTS AT THE BUILDING WITH ARCHITECTURAL DRAWINGS.
11. WATER SERVICE ENTRANCE DESIGNS TO INCLUDE METERS AND BACKFLOW PREVENTERS TO MEET ALL STANDARDS AND REQUIREMENTS OF THE PORTLAND WATER DISTRICT.
12. THE CONTRACTOR SHALL NOTIFY THE ENGINEER OF ANY GRADE CHANGES THAT WILL IMPACT STORM DRAINAGE INFRASTRUCTURE OR OTHER UTILITIES.
13. UTILITIES WITHIN 5 FEET FROM FACE OF BUILDING ARE COORDINATED ON RELEVANT M.E.P. DRAWINGS. CONTRACTOR SHALL COORDINATE INVERTS, CONNECTIONS AND MATERIALS WITH ALL DRAWINGS.
14. PROVIDE AN OIL BOOM IN EVERY CATCH BASIN WITHIN A PAVED AREA.
15. CONTRACTOR SHALL FURNISH AND INSTALL TRENCHING, MATERIALS AND BACKFILL FOR ALL UTILITIES. ELECTRICAL AND TELECOM DATA PROVIDERS WILL PULL PRIMARY SERVICE TO TRANSFORMER AND PANEL. CONTRACTOR RESPONSIBLE FOR TIMING AND COORDINATION WITH UTILITIES AND DRAWINGS. COORDINATE WITH ELECTRICAL DRAWINGS FOR CONDUIT SCHEDULE, TYPE AND SIZES.
16. COORDINATE ALL WATER RELATED WORK WITH PORTLAND WATER DISTRICT.
17. UTILITY CONTACTS:
ELECTRIC:
CENTRAL MAINE POWER (CMP)
NAME, TITLE - TBD
TELEPHONE - TBD
JOB # TBD
ACCOUNT # TBD
WATER:
PORTLAND WATER DISTRICT
207-774-5961
PIPELINE:
PORTLAND PIPELINE
JAY MAGEE
207-787-0415
SPECTRUM:
NAME - TBD
TELEPHONE - TBD
18. WELL TO BE DRILLED BY OTHERS. ELECTRICAL CONNECTION, PUMP SIZING, GROUNDWATER TESTING AND OTHER RELATED SERVICES TO BE COORDINATED BY WELL DRILLER WITH DESIGN ENGINEER, MECHANICAL ENGINEER AND ELECTRICAL ENGINEER.
19. STAGING AND BID ITEM INFORMATION REGARDING UTILITIES CAN BE REFERENCED ON SHEET PS003 AND SHALL BE COORDINATED WITH ARCHITECTURAL, MECHANICAL AND ELECTRICAL PLANS.

LANDSCAPE NOTES

- 1. PLANT QUANTITIES SHOWN ON PLANT LISTS ARE FOR CONVENIENCE TO THE CONTRACTOR ONLY. THE CONTRACTOR IS RESPONSIBLE FOR ALL PLANT MATERIAL INSTALLATION AS SHOWN ON PLANS.
2. SIZE AND GRADING STANDARDS OF PLANT MATERIALS SHALL CONFORM TO THE LATEST EDITION OF "U.S.A. STANDARD FOR NURSERY STOCK," BY THE AMERICAN ASSOCIATION OF NURSERYMEN, INC.
3. ALL PLANT MATERIAL SHALL BE FREE FROM INSECTS AND DISEASE.
4. ALL PLANTING SHALL BE DONE IN ACCORDANCE WITH ACCEPTABLE HORTICULTURAL PRACTICES. THIS IS TO INCLUDE PROPER PLANTING MIX, PLANT BED AND TREE PIT PREPARATION, PRUNING, STAKING OR GUYING, WRAPPING, SPRAYING, FERTILIZATION, PLANTING AND ADEQUATE MAINTENANCE UNTIL ACCEPTANCE BY THE OWNER.
5. PLANT MATERIAL SHALL BE GUARANTEED FOR A PERIOD OF ONE YEAR BY THE CONTRACTOR AND A PERIOD OF TWO YEARS THEREAFTER BY THE OWNER FROM DATE OF INSTALLATION. DURING THE ONE YEAR GUARANTEE PERIOD, DEAD PLANT MATERIAL SHALL BE REPLACED AT NO COST TO THE OWNER. AT THE END OF THE ONE YEAR PERIOD, THE CONTRACTOR SHALL OBTAIN FINAL ACCEPTANCE FROM THE OWNER.
6. ALL GRASS, OTHER VEGETATION AND DEBRIS SHALL BE REMOVED FROM ALL PLANTING AREAS PRIOR TO PLANTING.
7. EXISTING TREES TO BE PRESERVED WILL BE PROTECTED DURING CONSTRUCTION AND SHALL BE THE RESPONSIBILITY OF THE GENERAL CONTRACTOR.
8. THE LANDSCAPE CONTRACTOR IS ADVISED OF THE PRESENCE OF THE UNDERGROUND UTILITIES AND SHALL VERIFY THE EXISTENCE AND LOCATION OF SAME BEFORE COMMENCING AND DIGGING OPERATIONS. THE LANDSCAPE CONTRACTOR SHALL REPLACE OR REPAIR UTILITIES, PAVING, WALKS, CURBING, ETC. DAMAGED IN PERFORMANCE OF THIS JOB AT NO ADDITIONAL COST TO THE OWNER.
9. ALL SHRUB BEDS SHALL BE MULCHED WITH 3" CLEAN SHREDDED DARK BROWN BARK MULCH.
10. THE CONTRACTOR SHALL PROVIDE 4" LOAM FOR ALL AREAS TO BE SODDED OR SEEDED. PLANTING AREAS SHALL RECEIVE 12" ROLLED THICKNESS OF LOAM. THE LANDSCAPE CONTRACTOR SHALL COORDINATE SUBGRADE PREPARATION WITH THE GENERAL CONTRACTOR PRIOR TO PLACING LOAM.
11. ANY DEVIATION FROM THE LANDSCAPE PLAN, INCLUDING PLANT LOCATION, SELECTION, SIZE QUANTITY OR CONDITION SHALL BE REVIEWED AND APPROVED BY THE OWNER AND LANDSCAPE ARCHITECT (AND MUNICIPAL AUTHORITY, IF APPLICABLE) PRIOR TO INSTALLATION ON SITE.
12. WHERE INDICATED ON PLAN, PLANTING SOIL MIXTURE FOR PERENNIAL AND ANNUAL FLOWER BED AREAS SHALL CONSIST OF FOUR PARTS TOPSOIL, TWO PARTS SPHAGNUM PEAT MOSS, AND ONE PART HORTICULTURAL PERLITE BY VOLUME. PEAT MOSS MAY BE SUBSTITUTED WITH WELL-ROTTED OR DEHYDRATED MANURE OR COMPOST. ROTOTILL BEDS TO A DEPTH OF 8 INCHES.
13. DURING CLEANING OF SITE AND PRIOR TO TREE AND SHRUB INSTALLATION, CONTRACTOR SHALL REMOVE INVASIVE PLANTS. AREAS WHERE INVASIVE PLANTS ARE REMOVED AND NO OTHER PLANTING IS PROPOSED, AREA SHALL BE LOAM AND SEEDED.

TYPICAL ABBREVIATIONS

Table listing common abbreviations and their full names, such as AC (ACRE), AFG (ABOVE FINISH GRADE), APPROX. (APPROXIMATELY), BCC (BOTTOM OF CURB), BLDG (BUILDING), etc.



Revision table with columns for REV. NO., DATE, and DESCRIPTION. Includes entries for MVEI 9/14/22, MVEI 7/12/21, and MVEI 6/29/21.

SEBAGO TECHNICALS logo and contact information: 75 John Roberts Rd., Sullis, IA, South Portland, ME 04106, Tel. 207-200-2100.

NOTES & LEGENDS section for JORDAN BAY MARINA and PORT HARBOR MARINE, including project location and contact details.

Design and drawing status table: DESIGNED (JSH), DRAWN (DAB), CHECKED (RAM), DATE (06/22/22), SCALE (NTS), PROJECT (14265-02).

**ROOSEVELT TRAIL
(ROUTE 302)**

DEMOLITION NOTES

1. SEE THE EROSION CONTROL NOTES & DETAILS PLAN FOR EROSION CONTROL MEASURES TO BE INSTALLED PRIOR TO SITE DISTURBANCE.
2. CONTRACTOR SHALL NOTIFY DIGSAFE FOR UTILITY LOCATIONS PRIOR TO EXCAVATION.
3. ALL DEMOLITION WORK SHALL BE PERFORMED IN ACCORDANCE WITH ALL APPLICABLE CODES AND REGULATIONS.
4. ALL SITE FEATURES COLORED RED ARE TO BE DEMOLISHED AND/OR REMOVED FROM THE SITE.
5. WITHIN SAW CUT LIMITS REMOVE ALL ASPHALT AND CONCRETE.
6. CONTRACTOR RESPONSIBLE FOR COORDINATION WITH UTILITY SERVICE PROVIDER FOR REMOVAL, RELOCATION AND/OR PROTECTION OF UTILITY SERVICES.

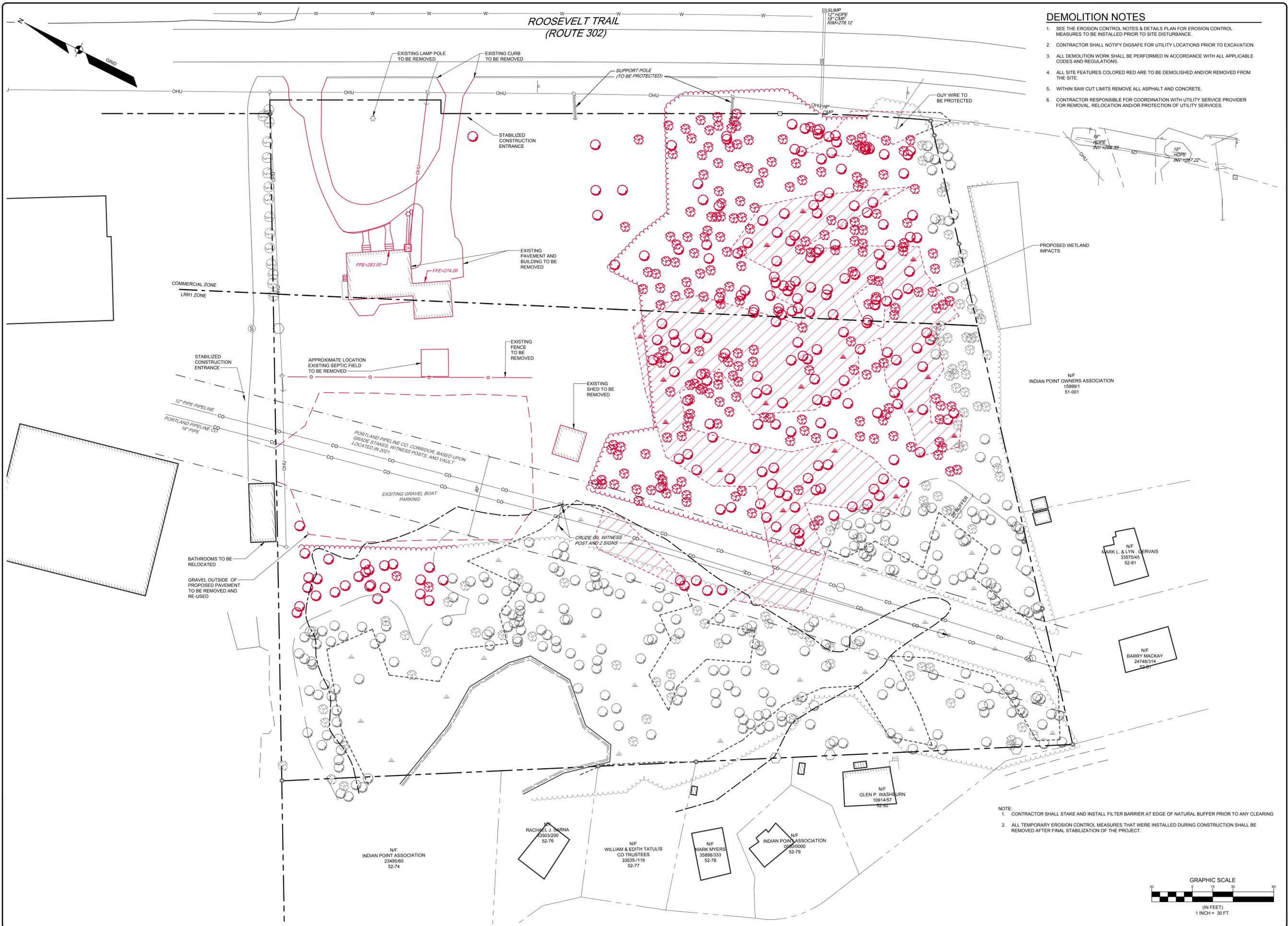

- NOTE:
1. CONTRACTOR SHALL STAKE AND INSTALL FILTER BARRIER AT EDGE OF NATURAL BUFFER PRIOR TO ANY CLEARING
 2. ALL TEMPORARY EROSION CONTROL MEASURES THAT WERE INSTALLED DURING CONSTRUCTION SHALL BE REMOVED AFTER FINAL STABILIZATION OF THE PROJECT.

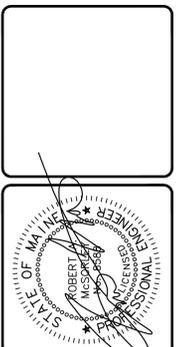
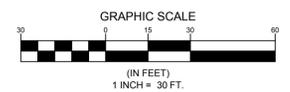

C	MW/E	9/14/22	REVISED PER TOWN OF RAYMOND COMMENTS
B	MW/E	7/12/21	REVISED PER REVIEW COMMENTS
A	MW/E	6/29/21	RELEASED FOR CLIENT REVIEW
REV.	BY:	DATE:	STATUS:

THIS PLAN SHALL NOT BE MODIFIED WITHOUT WRITTEN PERMISSION FROM SEBAGO TECHNICS, INC. ANY ALTERATIONS, AUTHORIZED OR OTHERWISE, SHALL BE AT THE USER'S SOLE RISK AND WITHOUT LIABILITY TO SEBAGO TECHNICS, INC.

SEBAGO
TECHNICS
WWW.SEAGOTECHNICS.COM
75 John Roberts Rd.
Sullivan, ME 04106
South Portland, ME 04106
Tel. 207-200-2100

DEMOLITION & EROSION CONTROL PLAN
OF:
JORDAN BAY MARINA
1328 ROOSEVELT TRAIL
RAYMOND, ME
FOR:
PORT HARBOR MARINE
1 SPRING POINT DRIVE
SOUTH PORTLAND, ME 04106

DESIGNED	JSH
DRAWN	DAB
CHECKED	RAM
DATE	06/22/22
SCALE	1" = 30'
PROJECT	14265-02

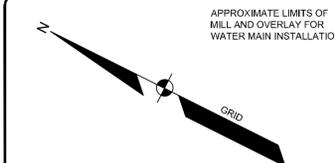
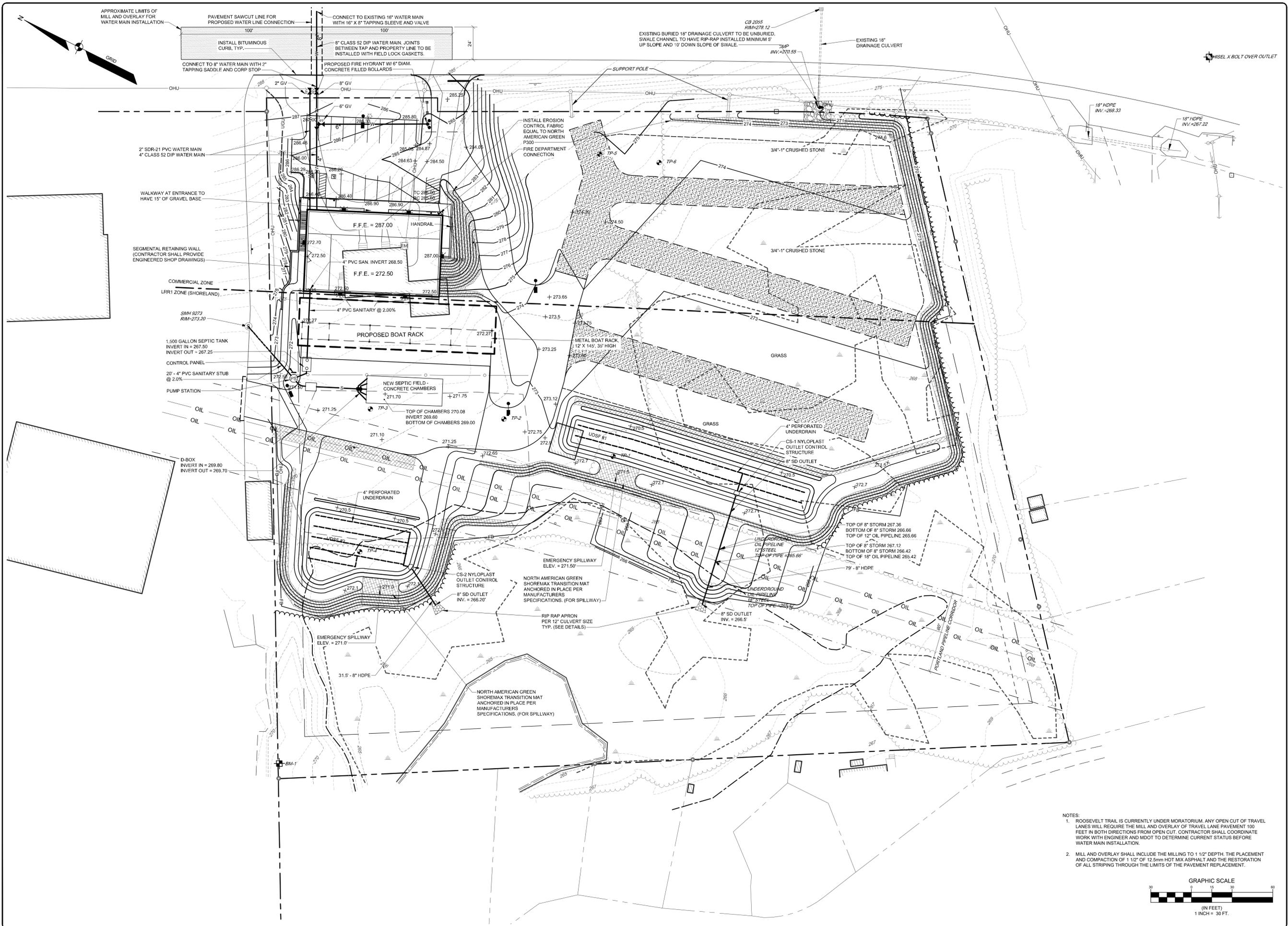

- NOTES:
- ROOSEVELT TRAIL IS CURRENTLY UNDER MORATORIUM. ANY OPEN CUT OF TRAVEL LANES WILL REQUIRE THE MILL AND OVERLAY OF TRAVEL LANE PAVEMENT 100 FEET IN BOTH DIRECTIONS FROM OPEN CUT. CONTRACTOR SHALL COORDINATE WORK WITH ENGINEER AND MDT TO DETERMINE CURRENT STATUS BEFORE WATER MAIN INSTALLATION.
 - MILL AND OVERLAY SHALL INCLUDE THE MILLING TO 1 1/2" DEPTH. THE PLACEMENT AND COMPACTION OF 1 1/2" OF 12.5mm HOT MIX ASPHALT AND THE RESTORATION OF ALL STRIPING THROUGH THE LIMITS OF THE PAVEMENT REPLACEMENT.

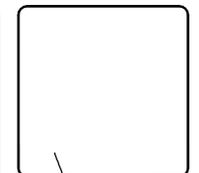
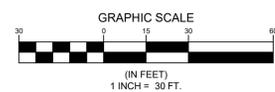

REVISIONS:

NO.	DATE	BY	REVISION
C	9/14/22	MMW	REVISED PER TOWN OF RAYMOND COMMENTS
B	7/12/21	MMW	REVISED PER REVIEW COMMENTS
A	6/29/21	MMW	RELEASED FOR CLIENT REVIEW

STATUS: _____
 DATE: _____

THIS PLAN SHALL NOT BE MODIFIED WITHOUT WRITTEN PERMISSION FROM SEBAGO TECHNIQS, INC. ANY ALTERATIONS, AUTHORIZED OR OTHERWISE, SHALL BE AT THE USER'S SOLE RISK AND WITHOUT LIABILITY TO SEBAGO TECHNIQS, INC.

SEBAGO
 TECHNICS
 WWW.SEBAGOTECHNIQS.COM
 75 John Roberts Rd.
 Sullis, ME 04106
 South Portland, ME 04106
 Tel. 207-200-2100

GRADING & UTILITIES PLAN
 OF:
JORDAN BAY MARINA
 1328 ROOSEVELT TRAIL
 RAYMOND, ME

FOR:
PORT HARBOR MARINE
 1 SPRING POINT DRIVE
 SOUTH PORTLAND, ME 04106

DESIGNED	JSH
DRAWN	DAB
CHECKED	RAM
DATE	06/22/22
SCALE	1" = 30'
PROJECT	14265-02

SHEET 6 OF 13

14265-02 Grading, Tab 6 Grading & Utilities Plan

EROSION CONTROL MEASURES

PRE-CONSTRUCTION PHASE

PRIOR TO THE BEGINNING OF ANY CONSTRUCTION, SEDIMENT BARRIERS (SILT FENCE) WILL BE STAKED/INSTALLED ACROSS THE SLOPE(S), ON THE CONTOUR AT OR JUST BELOW THE LIMITS OF CLEARING OR GRUBBING, AND/OR JUST ABOVE ANY ADJACENT PROPERTY LINE OR WATERCOURSE TO PROTECT AGAINST CONSTRUCTION RELATED EROSION. THE PLACEMENT OF SEDIMENT BARRIERS SHALL BE COMPLETED IN ACCORDANCE WITH GUIDELINES ESTABLISHED IN BEST MANAGEMENT PRACTICES AND IN ACCORDANCE WITH THIS EROSION CONTROL PLAN AND DETAILS IN THIS PLAN SET. THIS NETWORK IS TO BE MAINTAINED BY THE CONTRACTOR UNTIL ALL EXPOSED SLOPES HAVE AT LEAST 90% VIGOROUS PERENNIAL VEGETATIVE COVER TO PREVENT EROSION. TEMPORARY EROSION CONTROL MEASURES SHALL BE REMOVED WITHIN 30 DAYS AFTER PERMANENT STABILIZATION IS ATTAINED.

PRIOR TO ANY CLEARING OR GRUBBING, A CONSTRUCTION ENTRANCE/EXIT SHALL BE CONSTRUCTED AT THE INTERSECTION OF THE PROPOSED ENTRANCES AND EXISTING ROADWAY TO AVOID TRACKING OF MUD, DUST AND DEBRIS FROM THE SITE.

PRIOR TO CONSTRUCTION, THE CONTRACTOR SHALL PREPARE A DETAILED SCHEDULE AND MARKED UP PLAN INDICATING AREAS AND COMPONENTS OF THE WORK AND KEY DATES SHOWING DATE OF DISTURBANCE AND COMPLETION OF THE WORK. THE CONTRACTOR SHALL SUBMIT A PRE-CONSTRUCTION MEETING WITH THE MUNICIPAL STAFF. THREE COPIES OF THE SCHEDULE AND MARKED UP PLAN SHALL BE PROVIDED TO THE MUNICIPALITY THREE DAYS PRIOR TO THE SCHEDULED PRE-CONSTRUCTION MEETING. SPECIAL ATTENTION SHALL BE GIVEN TO THE 14 DAY LIMIT OF DISTURBANCE IN THE SCHEDULE ADDRESSING TEMPORARY AND PERMANENT VEGETATION MEASURES.

CONSTRUCTION AND POST-CONSTRUCTION PHASE

AREAS UNDERGOING ACTUAL CONSTRUCTION SHALL ONLY EXPOSE THAT AMOUNT OF MINERAL SOIL NECESSARY FOR PROGRESSIVE AND EFFICIENT CONSTRUCTION. AN AREA CONSIDERED OPEN IS ANY AREA NOT STABILIZED WITH PAVEMENT, VEGETATION, MULCHING, EROSION CONTROL MATS, RIPRAP OR GRAVEL BASE ON A ROAD, SUCH AS ACTIVE EXCAVATION AND ACTIVE GRADING. LIMIT THE EXPOSED AREA TO THOSE AREAS IN WHICH WORK IS ACTIVELY OCCURRING OR CAN BE MULCHED IN THE SAME DAY. OPEN AREAS SHALL BE ANCHORED WITH TEMPORARY EROSION CONTROL AS SHOWN ON THE DESIGN PLANS AND AS DESCRIBED WITHIN THIS EROSION CONTROL PLAN WITHIN SEVEN (7) DAYS OF DISTURBANCE. AREAS LOCATED WITHIN 100 FEET OF STREAMS SHALL BE ANCHORED WITH TEMPORARY EROSION CONTROL WITHIN SEVEN (7) DAYS. REFER TO WINTER EROSION CONTROL NOTES FOR THE TREATMENT OF OPEN AREAS AFTER OCTOBER 1ST OF THE CONSTRUCTION YEAR.

THE CONTRACTOR MUST INSTALL ANY ADDED MEASURES WHICH MAY BE NECESSARY TO CONTROL EROSION/SEDIMENTATION FROM THE SITE DEPENDENT UPON THE ACTUAL SITE AND WEATHER CONDITIONS. CONTINUATION OF EARTHWORK OPERATIONS ON ADDITIONAL AREAS SHALL NOT BEGIN UNTIL THE EXPOSED SOIL SURFACE ON THE AREA BEING WORKED HAS BEEN STABILIZED, IN ORDER TO MINIMIZE AREAS WITHOUT EROSION CONTROL PROTECTION.

EROSION CONTROL APPLICATIONS & MEASURES

THE PLACEMENT OF EROSION CONTROL MEASURES SHALL BE COMPLETED IN ACCORDANCE WITH GUIDELINES ESTABLISHED IN BEST MANAGEMENT PRACTICES AND IN ACCORDANCE WITH THE EROSION CONTROL PLAN AND DETAILS IN THE PLAN SET.

1. TEMPORARY MULCHING:

ALL DISTURBED AREAS SHALL BE MULCHED WITH MATERIALS SPECIFIED BELOW PRIOR TO ANY STORM EVENT. ALL DISTURBED AREAS NOT FINAL GRADED WITHIN 14 DAYS SHALL BE MULCHED. DISTURBED AREAS ADJACENT TO NATURAL RESOURCES THAT ARE NOT GRADED WITHIN SEVEN (7) DAYS SHALL BE MULCHED ALSO. AREAS WHICH HAVE BEEN TEMPORARILY OR PERMANENTLY SEEDED, SHALL BE MULCHED IMMEDIATELY FOLLOWING SEEDING. EROSION CONTROL BLANKETS ARE RECOMMENDED TO BE USED AT THE BASE OF GRASSED WATERWAYS AND ON SLOPES GREATER THAN 33%. MULCH ANCHORING SHOULD BE USED ON SLOPES GREATER THAN 5% AFTER SEPTEMBER 15TH OF THE CONSTRUCTION YEAR (SEE WINTER EROSION CONTROL NOTES).

TYPES OF MULCH:

HAY OR STRAW SHALL BE APPLIED AT A RATE OF 75 LBS/1,000 S.F. (1.5 TONS PER ACRE).

EROSION CONTROL MIX SHALL BE PLACED EVENLY AND MUST PROVIDE 100% SOIL COVERAGE. EROSION CONTROL MIX SHALL BE APPLIED SUCH THAT THE THICKNESS ON SLOPES 3:1 OR LESS IS 2 INCHES PLUS 1/2 INCH PER 20 FEET OF SLOPE UP TO 100 FEET. THE THICKNESS ON SLOPES BETWEEN 3:1 AND 2:1 SHALL BE 4 INCHES PLUS 1/2 INCH PER 20 FEET OF SLOPE UP TO 100 FEET. THIS SHALL NOT BE USED ON SLOPES GREATER THAN 2:1.

EROSION CONTROL BLANKET SHALL BE INSTALLED SUCH THAT CONTINUOUS CONTACT BETWEEN THE MAT AND THE SOIL IS MAINTAINED. INSTALL BLANKETS AND STAPLE IN ACCORDANCE WITH THE MANUFACTURER'S RECOMMENDATIONS.

2. SOIL STOCKPILES:

STOCKPILES OF SOIL OR SUBSOIL SHALL BE MULCHED WITH HAY OR STRAW AT A RATE OF 75 LBS/1,000 S.F. (1.5 TONS PER ACRE) OR WITH A FOUR-INCH LAYER OF WOOD WASTE EROSION CONTROL MIX. THIS WILL BE DONE WITHIN 24 HOURS OF STOCKING AND RE-ESTABLISHED PRIOR TO ANY RAINFALL. ANY SOIL STOCKPILE WILL NOT BE PLACED (EVEN COVERED WITH HAY OR STRAW) WITHIN 100 FEET FROM ANY NATURAL RESOURCES. SEDIMENT BARRIERS SHALL BE INSTALLED DOWNGRADIENT OF STOCKPILES, AND STORMWATER SHALL BE PREVENTED FROM RUNNING ONTO THE STOCKPILE.

3. NATURAL RESOURCES PROTECTION:

ANY AREAS WITHIN 100 FEET FROM ANY NATURAL RESOURCES SHALL BE MULCHED USING TEMPORARY MULCHING (AS DESCRIBED IN PART 1 OF THIS SECTION) WITHIN 7 DAYS OF EXPOSURE OR PRIOR TO ANY STORM EVENT. SEDIMENT BARRIERS (AS DESCRIBED IN PART 4 OF THIS SECTION) SHALL BE PLACED BETWEEN ANY NATURAL RESOURCE AND THE DISTURBED AREA. PROJECTS CROSSING THE NATURAL RESOURCE SHALL BE PROTECTED A MINIMUM DISTANCE OF 100 FEET ON EITHER SIDE FROM THE RESOURCE.

4. SEDIMENT BARRIERS:

PRIOR TO THE BEGINNING OF ANY CONSTRUCTION, SEDIMENT BARRIERS SHALL BE STAKED ACROSS THE SLOPE(S), ON THE CONTOUR AT OR JUST BELOW THE LIMITS OF CLEARING OR GRUBBING, AND/OR JUST ABOVE ANY ADJACENT PROPERTY LINE OR WATERCOURSE TO PROTECT AGAINST CONSTRUCTION RELATED EROSION. SEDIMENT BARRIERS SHALL BE MAINTAINED BY THE CONTRACTOR UNTIL ALL EXPOSED SLOPES HAVE AT LEAST 90% VIGOROUS PERENNIAL VEGETATIVE COVER TO PREVENT EROSION.

SILT FENCE SHALL BE INSTALLED PER THE DETAIL ON THE PLANS. THE EFFECTIVE HEIGHT OF THE FENCE SHALL NOT EXCEED 36 INCHES. IT IS RECOMMENDED THAT SILT FENCE BE REMOVED BY CUTTING THE FENCE MATERIALS AT GROUND LEVEL SO AS TO AVOID ADDITIONAL SOIL DISTURBANCE.

HAY BALES SHALL NOT BE INSTALLED ADJACENT TO WETLAND. INSTALL PER THE DETAIL ON THE PLANS. BALES SHALL BE WIRE-BOUND OR STRING-TIED AND THESE BINDINGS MUST REMAIN PARALLEL WITH THE GROUND SURFACE DURING INSTALLATION TO PREVENT DETERIORATION OF THE BINDINGS. BALES SHALL BE INSTALLED WITHIN A MINIMUM 4 INCH DEEP TRENCH LINE WITH ENDS OF ADJACENT BALES TIGHTLY ABUTTING ONE ANOTHER.

EROSION CONTROL MIX SHALL NOT BE USED ADJACENT TO WETLANDS. INSTALL PER THE DETAIL ON THE PLANS. THE MIX SHALL CONSIST PRIMARILY OF ORGANIC MATERIAL AND CONTAIN A WELL-GRADED MIXTURE OF PARTICLE SIZES AND MAY CONTAIN ROCKS LESS THAN 4 INCHES IN DIAMETER. THE MIX COMPOSITION SHALL MEET THE STANDARDS DESCRIBED WITHIN THE MDEP BEST MANAGEMENT PRACTICES. NO TRENCHING IS REQUIRED FOR INSTALLATION OF THIS BARRIER. EROSION CONTROL MIX BERMS SHALL NOT BE USED AT THE BOTTOM OF STEEP SLOPES (>8%) OR SLOPES WITH FLOWING WATER.

CONTINUOUS CONTAINED BERM SHALL BE INSTALLED PER THE DETAIL ON THE PLANS. THIS SEDIMENT BARRIER IS EROSION CONTROL MIX PLACED WITHIN A SYNTHETIC TUBULAR NETTING AND PERFORMS AS A STURDY SEDIMENT BARRIER THAT WORKS WELL ON HARD GROUND SUCH AS FROZEN CONDITIONS, TRAVELED AREAS OR PAVEMENT. NO TRENCHING IS REQUIRED FOR INSTALLATION OF THIS BARRIER.

5. TEMPORARY CHECK DAMS:

SHALL BE INSTALLED PER THE DETAIL ON THE PLANS. CHECK DAMS ARE TO BE PLACED WITHIN DITCHES/ SWALES AS SPECIFIED ON THE DESIGN PLANS IMMEDIATELY AFTER FINAL GRADING. CHECK DAMS SHALL BE 2 FEET HIGH. TEMPORARY CHECK DAMS MAY BE REMOVED ONLY AFTER THE ROADWAYS ARE PAVED AND THE VEGETATED SWALE ARE ESTABLISHED WITH AT LEAST 90% OF VIGOROUS PERENNIAL GROWTH. THE AREA BENEATH THE CHECK DAM MUST BE SEEDED AND MULCHED IMMEDIATELY AFTER REMOVAL OF THE CHECK DAM.

STONE CHECK DAMS: STONE DAMS SHOULD BE CONSTRUCTED OF 2 TO 3 INCH STONE AND PLACED SUCH THAT COMPLETE COVERAGE OF THE SWALE IS OBTAINED AND THAT THE CENTER OF THE DAM IS 6 INCHES LOWER THAT THE OUTER EDGES.

HAY BALE CHECK DAMS: BALES SHALL BE WIRE-BOUND OR STRING-TIED. BALES SHALL BE INSTALLED WITHIN A MINIMUM 4 INCH DEEP TRENCH LINE WITH ENDS OF ADJACENT BALES TIGHTLY ABUTTING ONE ANOTHER. HAY BALES SHALL BE PLACED SUCH THAT COMPLETE COVERAGE OF THE SWALE IS OBTAINED AND THAT THE CENTER OF THE DAM IS 6 INCHES LOWER THAT THE OUTER EDGES.

MANUFACTURED CHECK DAMS: MANUFACTURED CHECK DAMS, AS SPECIFIED IN THE DETAIL ON THE PLANS, MAY BE USED IF AUTHORIZED BY THE PROPER LOCAL, STATE OR FEDERAL REGULATING AGENCIES. THESE UNITS SHALL BE INSTALLED IN ACCORDANCE WITH THE MANUFACTURER'S RECOMMENDATIONS.

6. STORMDRAIN INLET PROTECTION:

INLET PROTECTION SHALL BE PLACED AROUND A STORMDRAIN DROP INLET OR CURB INLET PRIOR TO PERMANENT STABILIZATION OF THE IMMEDIATE AND UPSTREAM DISTURBED AREAS. THEY SHALL BE CONSTRUCTED IN A MANNER THAT WILL FACILITATE CLEAN-OUT AND DISPOSAL OF TRAPPED SEDIMENTS AND MINIMIZE INTERFERENCE WITH CONSTRUCTION ACTIVITIES. ANY RESULTANT PONDING OF WATER FROM THE PROTECTION METHOD MUST NOT CAUSE EXCESSIVE INCONVENIENCE OR DAMAGE TO ADJACENT AREAS OR STRUCTURES.

HAY BALE DROP INLET PROTECTION: WE DO NOT RECOMMEND THE USE OF HAY BALES AS INLET PROTECTION.

CONCRETE BLOCK AND STONE INLET SEDIMENT FILTER (DROP OR CURB INLET): SHALL BE INSTALLED PER THE DETAIL ON THE PLANS. THE HEIGHT OF THE CONCRETE BLOCK BARRIER CAN VARY BUT MUST BE BETWEEN 12 AND 24 INCHES TALL. A MINIMUM OF 1 INCH CRUSHED STONE SHALL BE USED.

MANUFACTURED SEDIMENT BARRIERS AND FILTER (DROP OR CURB INLET): MANUFACTURED FILTERS, AS SPECIFIED IN THE DETAIL ON THE PLANS, MAY BE USED IF INSTALLED IN ACCORDANCE WITH THE MANUFACTURER'S RECOMMENDATIONS.

7. STABILIZED CONSTRUCTION ENTRANCE/EXIT:

PRIOR TO CLEARING AND/OR GRUBBING THE SITE A STABILIZED CONSTRUCTION ENTRANCE/EXIT SHALL BE CONSTRUCTED WHEREVER TRAFFIC WILL EXIT THE CONSTRUCTION SITE ONTO A PAVED ROADWAY IN ORDER TO MINIMIZE THE TRACKING OF SEDIMENT AND DEBRIS FROM THE CONSTRUCTION SITE ONTO PUBLIC ROADWAYS. THE ENTRANCES AND ADJACENT ROADWAY AREAS SHALL BE PERIODICALLY SWEEPED TO FURTHER MINIMIZE THE TRACKING OF MUD, DUST OR DEBRIS FROM THE CONSTRUCTION AREA. THE TERM "SWEEP" IS UNDERSTOOD TO MEAN REMOVAL AND RECOVERY OF TRACKED SEDIMENT WITH A STREET SWEEPER, NOT BRUSHING THE MATERIAL INTO SWALES OR STRUCTURES WITH A MECHANICAL BROOM. STABILIZED CONSTRUCTION EXITS SHALL BE CONSTRUCTED IN AREAS SPECIFIED ON THE PLANS AND AS DETAILED ON THE PLANS. THE CONTRACTOR SHALL MAINTAIN THE STABILIZED CONSTRUCTION ENTRANCE UNTIL ALL DISTURBED AREAS ARE STABILIZED.

DUST CONTROL:

DUST CONTROL DURING CONSTRUCTION SHALL BE ACHIEVED BY THE USE OF A WATERING TRUCK TO PERIODICALLY SPRINKLE THE EXPOSED ROADWAY AREAS AS NECESSARY TO REDUCE DUST DURING THE DRY MONTHS. APPLYING OTHER DUST CONTROL PRODUCTS SUCH AS CALCIUM CHLORIDE OR OTHER MANUFACTURED PRODUCTS ARE ALLOWED IF AUTHORIZED BY THE PROPER LOCAL, STATE AND/OR FEDERAL REGULATING AGENCIES. HOWEVER, IT IS THE CONTRACTOR'S ULTIMATE RESPONSIBILITY TO MITIGATE DUST AND SOIL LOSS FROM THE SITE. IF OFFSITE TRACKING OCCURS, PUBLIC ROADS SHOULD BE SWEEP IMMEDIATELY AND NOT LESS THAN ONCE A WEEK AND PRIOR TO SIGNIFICANT STORM EVENTS.

TEMPORARY VEGETATION:

TEMPORARY VEGETATION SHALL BE APPLIED TO DISTURBED AREAS THAT WILL NOT RECEIVE FINAL GRADING FOR PERIODS UP TO 12 MONTHS. THIS PROCEDURE SHOULD BE USED EXTENSIVELY IN AREAS ADJACENT TO NATURAL RESOURCES. SEEDBED PREPARATION AND APPLICATION OF SEED SHALL BE CONDUCTED AS INDICATED IN THE PERMANENT VEGETATION SECTION OF THIS NARRATIVE. SPECIFIC SEEDS (FAST GROWING AND SHORT LIVING) SHALL BE SELECTED FROM THE MAINE EROSION AND SEDIMENT CONTROL BMP MANUALS FOR CONTRACTORS AND ENGINEERS, LATEST REVISION. ALTERNATIVE EROSION CONTROL MEASURES SHOULD BE USED IF SEEDING CAN NOT BE DONE BEFORE SEPTEMBER 15TH OF THE CONSTRUCTION YEAR.

PERMANENT VEGETATION:

REVEGETATION MEASURES SHALL COMMENCE IMMEDIATELY UPON COMPLETION OF FINAL GRADING OF AREAS TO BE LOAMED AND SEEDED. THE APPLICATION OF SEED SHALL BE CONDUCTED BETWEEN APRIL 1ST AND OCTOBER 1ST OF THE CONSTRUCTION YEAR. PLEASE REFER TO THE WINTER EROSION CONTROL NOTES FOR MORE DETAIL. REVEGETATION MEASURES SHALL CONSIST OF THE FOLLOWING:

SEEDBED PREPARATION:

A. FOUR (4) INCHES OF LOAM SHALL BE SPREAD OVER DISTURBED AREAS AND SMOOTHED TO A UNIFORM SURFACE. LOAM SHALL BE FREE OF SUBSOIL, CLAY LUMPS, STONES AND OTHER OBJECTS OVER 2 INCHES OR LARGER IN ANY DIMENSION, AND WITHOUT WEEDS, ROOTS OR OTHER OBJECTIONABLE MATERIAL.

B. SOILS TESTS SHALL BE TAKEN AT THE TIME OF SOIL STRIPPING TO DETERMINE FERTILIZATION REQUIREMENTS. SOILS TESTS SHALL BE TAKEN PROMPTLY AS TO NOT INTERFERE WITH THE 14-DAY LIMIT ON SOIL EXPOSURE. BASED UPON TEST RESULTS, SOIL AMENDMENTS SHALL BE INCORPORATED INTO THE SOIL PRIOR TO FINAL SEEDING. IN LIEU OF SOIL TESTS, SOIL AMENDMENTS MAY BE APPLIED AS FOLLOWS:

ITEM	APPLICATION RATE
------	------------------

10-20-20 FERTILIZER (N-P205-K20 OR EQUIV.) 18.4 LBS/1,000 S.F.

GROUND LIMESTONE (50% CALCIUM & MAGNESIUM OXIDE) 138 LBS/1,000 S.F.

C. WORK LIIME AND FERTILIZER INTO THE SOIL AS NEARLY AS PRACTICAL TO A DEPTH OF 4 INCHES WITH PROPER EQUIPMENT. ROLL THE AREA TO FIRM THE SEEDBED EXCEPT ON CLAY OR SILTY SOILS OR COARSE SAND.

APPLICATION OF SEED:

A. SEEDING SHALL BE CONDUCTED BETWEEN APRIL 1ST AND OCTOBER 1ST OF THE CONSTRUCTION YEAR. GENERALLY A SEED MIXTURE MAY BE APPLIED AS FOLLOWS: (MDEP SEED MIX 2 IS DISPLAYED)

SEED TYPE	APPLICATION RATE
CREEPIING RED FESCUE	0.46 LBS/1,000 S.F. (20 LBS/ACRE)
REDTOP	0.05 LBS/1,000 S.F. (2 LBS/ACRE)
TALL FESCUE	0.46 LBS/1,000 S.F. (20 LBS/ACRE)
TOTAL:	0.97 LBS/1,000 S.F. (42 LBS/ACRE)

NOTE: A SPECIFIC SEED MIXTURE SHOULD BE CHOSEN TO MATCH THE SOILS CONDITION OF THE SITE. VARIOUS AGENCIES CAN RECOMMEND SEED MIXTURES. MDEP RECOMMENDED SEED MIXTURES ARE IN THE EROSION AND SEDIMENT CONTROL BMP MANUAL DATED 2016 OR LATEST REVISION.

B. HYDROSEEDING SHALL BE CONDUCTED ON PREPARED AREAS WITH SLOPES LESS THAN 2:1. LIIME AND FERTILIZER MAY BE APPLIED SIMULTANEOUSLY WITH THE SEED. RECOMMENDED SEEDING RATES MUST BE INCREASED BY 10% WHEN HYDROSEEDING.

C. MULCHING SHALL COMMENCE IMMEDIATELY AFTER SEED IS APPLIED. REFER TO THE TEMPORARY MULCHING SECTION OF THIS NARRATIVE FOR DETAILS.

SODDING: FOLLOWING SEEDBED PREPARATION, SOD CAN BE APPLIED IN LIEU OF SEEDING IN AREAS WHERE IMMEDIATE VEGETATION IS MOST BENEFICIAL, SUCH AS DITCHES, AROUND STORMWATER DROP INLETS AND AREAS OF AESTHETIC VALUE. SOD SHOULD BE LAID AT RIGHT ANGLES TO THE DIRECTION OF FLOW, STARTING AT THE LOWEST ELEVATION. SOD SHOULD BE ROLLED OR TAMPED DOWN TO EVEN OUT THE JOINTS ONCE LAID DOWN. WHERE FLOW IS PREVALENT THE SOD MUST BE PROPERLY ANCHORED DOWN. IRRIGATE THE SOD IMMEDIATELY AFTER INSTALLATION. IN MOST CASES, SOD CAN BE ESTABLISHED BETWEEN APRIL 1ST AND NOVEMBER 15TH OF THE CONSTRUCTION YEAR, HOWEVER, REFER TO THE WINTER EROSION CONTROL NOTES FOR ANY ACTIVITIES AFTER OCTOBER 1ST.

STANDARDS FOR TIMELY STABILIZATION:

STANDARD FOR THE TIMELY STABILIZATION OF DISTURBED SLOPES - THE CONTRACTOR WILL CONSTRUCT AND STABILIZE STONE-COVERED SLOPES BY NOVEMBER 15. THE CONTRACTOR WILL SEED AND MULCH ALL SLOPES TO BE VEGETATED BY SEPTEMBER 15. THE MDEP WILL CONSIDER ANY AREA HAVING A GRADE GREATER THAN 15% (10H:1V) TO BE A SLOPE. IF THE CONTRACTOR FAILS TO STABILIZE ANY SLOPE TO BE VEGETATED BY SEPTEMBER 15, THEN THE CONTRACTOR WILL TAKE ONE OF THE FOLLOWING ACTIONS TO STABILIZE THE SLOPE FOR LATE FALL AND WINTER.

- STABILIZE THE SOIL WITH TEMPORARY VEGETATION AND EROSION CONTROL MATS - BY OCTOBER 1 THE CONTRACTOR WILL SEED THE DISTURBED SOIL WITH WINTER RYE AT A SEEDING RATE OF 3 POUNDS PER 1000 SQUARE FEET AND APPLY EROSION CONTROL MATS OVER THE MULCHED SLOPE. THE CONTRACTOR WILL MONITOR GROWTH OF THE RYE OVER THE NEXT 30 DAYS. IF THE RYE FAILS TO GROW AT LEAST THREE INCHES OR COVER AT LEAST 75% OF THE DISTURBED SLOPE BY NOVEMBER 1, THEN THE APPLICANT WILL COVER THE SLOPE WITH A LAYER OF WOOD WASTE COMPOST AS DESCRIBED IN ITEM 2(C) OF THIS STANDARD OR WITH STONE RIPRAP AS DESCRIBED IN ITEM 2(D) OF THIS STANDARD.
- STABILIZE THE SOIL WITH SOD - THE CONTRACTOR WILL STABILIZE THE DISTURBED SOIL WITH PROPERLY INSTALLED SOD BY OCTOBER 1. PROPER INSTALLATION INCLUDES THE APPLICANT PINNING THE SOD ONTO THE SLOPE WITH WIRE PINS, ROLLING THE SOD TO GUARANTEE CONTACT BETWEEN THE SOD AND UNDERLYING SOIL, AND WATERING THE SOD TO PROMOTE ROOT GROWTH INTO THE DISTURBED SOIL. THE APPLICANT WILL NOT USE LATE-SEASON SOD INSTALLATION TO STABILIZE SLOPES HAVING A GRADE GREATER THAN 33% (3H:1V).
- STABILIZE THE SOIL WITH WOOD WASTE COMPOST - THE CONTRACTOR WILL PLACE A SIX-INCH LAYER OF WOOD WASTE COMPOST ON THE SLOPE BY NOVEMBER 15. PRIOR TO PLACING THE WOOD WASTE COMPOST, THE APPLICANT WILL REMOVE ANY SNOW ACCUMULATION ON THE DISTURBED SLOPE. THE APPLICANT WILL NOT USE WOOD WASTE COMPOST TO STABILIZE SLOPES HAVING GRADES GREATER THAN 50% (2H:1V) OR HAVING GROUNDWATER SEEPS ON THE SLOPE FACE.
- STABILIZE THE SOIL WITH STONE RIPRAP - THE CONTRACTOR WILL PLACE A LAYER OF STONE RIPRAP ON THE SLOPE BY NOVEMBER 15. THE APPLICANT WILL HIRE A REGISTERED PROFESSIONAL ENGINEER TO DETERMINE THE STONE SIZE NEEDED FOR STABILITY AND TO DESIGN A FILTER LAYER FOR UNDERNEATH THE RIPRAP.

STANDARD FOR THE TIMELY STABILIZATION OF DISTURBED SOILS - BY SEPTEMBER 15 THE CONTRACTOR WILL SEED AND MULCH ALL DISTURBED SOILS ON AREAS HAVING A SLOPE LESS THAN 15% (10H:1V). IF THE CONTRACTOR FAILS TO STABILIZE THESE SOILS BY THIS DATE, THEN THE CONTRACTOR WILL TAKE ONE OF THE FOLLOWING ACTIONS TO STABILIZE THE SOIL FOR LATE FALL AND WINTER.

- STABILIZE THE SOIL WITH TEMPORARY VEGETATION - BY OCTOBER 1 THE CONTRACTOR WILL SEED THE DISTURBED SOIL WITH WINTER RYE AT A SEEDING RATE OF 3 POUNDS PER 1000 SQUARE FEET, LIGHTLY MULCH THE SEEDED SOIL WITH HAY OR STRAW AT 75 POUNDS PER 1000 SQUARE FEET, AND ANCHOR THE MULCH WITH PLASTIC NETTING. THE APPLICANT WILL MONITOR GROWTH OF THE RYE OVER THE NEXT 30 DAYS. IF THE RYE FAILS TO GROW AT LEAST THREE INCHES OR COVER AT LEAST 75% OF THE DISTURBED SOIL BEFORE NOVEMBER 15, THEN THE APPLICANT WILL MULCH THE AREA FOR OVER-WINTER PROTECTION AS DESCRIBED IN ITEM 3(C) OF THIS STANDARD.
- STABILIZE THE SOIL WITH SOD - THE APPLICANT WILL STABILIZE THE DISTURBED SOIL WITH PROPERLY INSTALLED SOD BY OCTOBER 1. PROPER INSTALLATION INCLUDES THE APPLICANT PINNING THE SOD ONTO THE SOIL WITH WIRE PINS, ROLLING THE SOD TO GUARANTEE CONTACT BETWEEN THE SOD AND UNDERLYING SOIL, AND WATERING THE SOD TO PROMOTE ROOT GROWTH INTO THE DISTURBED SOIL.
- STABILIZE THE SOIL WITH MULCH - BY NOVEMBER 15 THE APPLICANT WILL MULCH THE DISTURBED SOIL BY SPREADING HAY OR STRAW AT A RATE OF AT LEAST 150 POUNDS PER 1000 SQUARE FEET. IF THE MULCH IS VISIBLE THROUGH THE MULCH, PRIOR TO APPLYING THE MULCH, THE APPLICANT WILL REMOVE ANY SNOW ACCUMULATION ON THE DISTURBED AREA. IMMEDIATELY AFTER APPLYING THE MULCH, THE APPLICANT WILL ANCHOR THE MULCH WITH PLASTIC NETTING TO PREVENT WIND FROM MOVING THE MULCH OFF THE DISTURBED SOIL.

- MAINTENANCE MEASURES SHALL BE APPLIED AS NEEDED DURING THE ENTIRE CONSTRUCTION CYCLE. AFTER EACH RAINFALL, SNOW STORM OR PERIOD OF THAWING AND RUNOFF, AND AT LEAST EVERY SEVEN (7) DAYS, THE CONTRACTOR SHALL PERFORM A VISUAL INSPECTION OF ALL INSTALLED EROSION CONTROL MEASURES. THE CONTRACTOR SHALL PERFORM REPAIRS NO LATER THAN THE END OF THE NEXT WORKDAY, TO ALLOW CONTINUED PROPER FUNCTIONING OF THE EROSION CONTROL MEASURE. THE CONTRACTOR SHALL PROVIDE THE NECESSARY REGULATING AGENCIES WITH WRITTEN DOCUMENTATION DESCRIBING DATES OF INSPECTIONS AND NECESSARY FOLLOW-UP WORK TO MAINTAIN EROSION CONTROL MEASURES MEETING THE REQUIREMENTS OF THIS PLAN WITHIN SEVEN (7) DAYS.
- FOLLOWING THE TEMPORARY AND/OR FINAL SEEDINGS, THE CONTRACTOR SHALL INSPECT THE WORK AREA SEMIMONTHLY UNTIL THE SEEDINGS HAVE BEEN ESTABLISHED. ESTABLISHED MEANS A MINIMUM OF 90% OF AREAS VEGETATED WITH VIGOROUS GROWTH. RESEEDING SHALL BE CARRIED OUT BY THE CONTRACTOR WITH FOLLOW-UP INSPECTIONS IN THE EVENT OF ANY FAILURES UNTIL VEGETATION IS ADEQUATELY ESTABLISHED.

HOUSEKEEPING:

1. SPILL PREVENTION: CONTROLS MUST BE USED TO PREVENT POLLUTANTS FROM CONSTRUCTION AND WASTE MATERIALS STORED ON SITE TO ENTER STORMWATER, WHICH INCLUDES STORAGE PRACTICES TO MINIMIZE EXPOSURE OF THE MATERIALS TO STORMWATER. THE SITE CONTRACTOR OR OPERATOR MUST DEVELOP, AND IMPLEMENT AS NECESSARY, APPROPRIATE SPILL PREVENTION, CONTAINMENT, AND RESPONSE PLANNING MEASURES.

2. GROUNDWATER PROTECTION: DURING CONSTRUCTION, LIQUID PETROLEUM PRODUCTS AND OTHER HAZARDOUS MATERIALS WITH THE POTENTIAL TO CONTAMINATE GROUNDWATER MAY NOT BE STORED OR HANDLED IN AREAS OF THE SITE DRAINING TO AN INFILTRATION AREA. AN "INFILTRATION AREA" IS ANY AREA OF THE SITE THAT BY DESIGN OR AS A RESULT OF SOILS, TOPOGRAPHY AND OTHER RELEVANT FACTORS ACCUMULATES RUNOFF THAT INFILTRATES INTO THE SOIL, DIKES, BERMS, SUBDRAINAGE, AND OTHER FORMS OF CONTAINMENT THAT PREVENT DISCHARGE TO GROUNDWATER. THE APPLICANT MAY BE USED TO ISOLATE PORTIONS OF THE SITE FOR THE PURPOSES OF STORAGE AND HANDLING OF THESE MATERIALS. ANY PROJECT PROPOSING INFILTRATION OF STORMWATER MUST PROVIDE ADEQUATE PRE-TREATMENT OF STORMWATER PRIOR TO DISCHARGE OF STORMWATER TO THE INFILTRATION AREA, OR PROVIDE FOR TREATMENT WITHIN THE INFILTRATION AREA, IN ORDER TO PREVENT THE ACCUMULATION OF FINES, REDUCTION IN INFILTRATION RATE, AND CONSEQUENT FLOODING AND DESTABILIZATION.

3. FUGITIVE SEDIMENT AND DUST: ACTIONS MUST BE TAKEN TO ENSURE THAT ACTIVITIES DO NOT RESULT IN NOTICEABLE EROSION OF SOILS OR FUGITIVE DUST EMISSIONS DURING OR AFTER CONSTRUCTION. OIL MAY NOT BE USED FOR DUST CONTROL, BUT OTHER WATER ADDITIVES MAY BE CONSIDERED AS NEEDED. A STABILIZED CONSTRUCTION ENTRANCE (SEE) SHOULD BE INCLUDED TO MINIMIZE TRACKING OF MUD AND SEDIMENT. IF OFF-SITE TRACKING OCCURS, PUBLIC ROADS SHOULD BE SWEEP IMMEDIATELY AND NO LESS THAN ONCE A WEEK AND PRIOR TO SIGNIFICANT STORM EVENTS. OPERATIONS DURING DRY MONTHS, THAT EXPERIENCE FUGITIVE DUST PROBLEMS, SHOULD WET DOWN UNPAVED ACCESS ROADS ONCE A WEEK OR MORE FREQUENTLY AS NEEDED WITH A WATER ADDITIVE TO SUPPRESS FUGITIVE SEDIMENT AND DUST.

4. DEBRIS AND OTHER MATERIALS: MINIMIZE THE EXPOSURE OF CONSTRUCTION DEBRIS, BUILDING AND LANDSCAPING MATERIALS, TRASH, FERTILIZERS, PESTICIDES, HERBICIDES, DETERGENTS, SANITARY WASTE AND OTHER MATERIALS TO PRECIPITATION AND STORMWATER RUNOFF. THESE MATERIALS MUST BE PREVENTED FROM BECOMING A POLLUTANT SOURCE.

5. EXCAVATION DE-WATERING: EXCAVATION DE-WATERING IS THE REMOVAL OF WATER FROM TRENCHES, FOUNDATIONS, COFFER DAMS, PONDS, AND OTHER AREAS WITHIN THE CONSTRUCTION AREA THAT RETAIN WATER. AFTER EXCAVATION, IN MOST CASES THE COLLECTED WATER IS HEAVILY SALTED AND HINDERS CORRECT AND SAFE CONSTRUCTION PRACTICES. THE COLLECTED WATER REMOVED FROM THE PONDED AREA, EITHER THROUGH GRAVITY OR PUMPING, MUST BE SPREAD THROUGH NATURAL WOODED BUFFERS OR REMOVED TO AREAS THAT ARE SPECIFICALLY DESIGNED TO COLLECT THE MAXIMUM AMOUNT OF SEDIMENT POSSIBLE, LIKE A COFFERDAM SEDIMENTATION BASIN. AVOID ALLOWING THE WATER TO FLOW OVER DISTURBED AREAS OF THE SITE. EQUIVALENT MEASURES MAY BE TAKEN IF APPROVED BY THE DEPARTMENT.

6. AUTHORIZED NON-STORMWATER DISCHARGES: IDENTIFY AND PREVENT CONTAMINATION BY NON-STORMWATER DISCHARGES, WHERE ALLOWED NON-STORMWATER DISCHARGES EXIST. THEY MUST BE IDENTIFIED AND STEPS SHOULD BE TAKEN TO ENSURE THE IMMEDIATE AND APPROPRIATE POLLUTION PREVENTION MEASURES FOR THE NON-STORMWATER COMPONENT(S) OF THE DISCHARGE. AUTHORIZED NON-STORMWATER DISCHARGES ARE:

- DISCHARGES FROM FIREFIGHTING ACTIVITY;
- FIRE HYDRANT FLUSHINGS;
- VEHICLE WASHWATER IF DETERGENTS ARE NOT USED AND WASHING IS LIMITED TO THE EXTERIOR OF VEHICLES (ENGINE, UNDERCARRIAGE AND TRANSMISSION WASHING IS PROHIBITED);
- DUST CONTROL RUNOFF IN ACCORDANCE WITH PERMIT CONDITIONS;
- ROUTINE EXTERIOR BUILDING WASHING, NOT INCLUDING SURFACE PAINT REMOVAL, THAT DOES NOT INVOLVE DETERGENTS;
- PAVEMENT WASHWATER (WHERE SPILLS/LEAKS OF TOXIC OR HAZARDOUS MATERIALS HAVE NOT OCCURRED, UNLESS ALL SPILLED MATERIAL HAD BEEN REMOVED) IF DETERGENTS ARE NOT USED;
- UNCONTAMINATED AIR CONDITIONING OR COMPRESSOR CONDENSATE;
- UNCONTAMINATED GROUNDWATER OR SPRING WATER;
- FOUNDATION OR FOOTER DRAIN-WATER WHERE FLOWS ARE NOT CONTAMINATED;
- UNCONTAMINATED EXCAVATION DEWATERING;
- POTABLE WATER SOURCES INCLUDING WATERLINE FLUSHINGS; AND
- LANDSCAPE IRRIGATION.

7. UNAUTHORIZED NON-STORMWATER DISCHARGES: THE DEPARTMENT'S APPROVAL DOES NOT AUTHORIZE A DISCHARGE THAT IS MIXED WITH A SOURCE OF NON-STORMWATER, OTHER THAN THOSE DISCHARGES SPECIFICALLY, THE DEPARTMENT'S APPROVAL DOES NOT AUTHORIZE DISCHARGES OF THE FOLLOWING:

- WASTEWATER FROM THE WASHOUT OR CLEAN OUT OF CONCRETE, STUCCO, PAINT, FORM RELEASE OILS, CURING COMPOUNDS OR OTHER CONSTRUCTION MATERIALS;
- FUELS, OILS OR OTHER POLLUTANTS USED IN VEHICLE AND EQUIPMENT OPERATION AND MAINTENANCE;
- SOAPS, SOLVENTS, OR DETERGENTS USED IN VEHICLE AND EQUIPMENT WASHING, AND
- TOXIC OR HAZARDOUS SUBSTANCES FROM A SPILL OR OTHER RELEASE.

WINTER EROSION CONTROL MEASURES

THE WINTER CONSTRUCTION PERIOD IS FROM NOVEMBER 1 THROUGH APRIL 15. IF THE CONSTRUCTION SITE IS NOT STABILIZED WITH PAVEMENT, A ROAD GRAVEL BASE, 75% MATURE VEGETATION COVER OR RIPRAP BY NOVEMBER 1 THEN THE SITE NEEDS TO BE PROTECTED WITH OVER-WINTER STABILIZATION. AN AREA CONSIDERED OPEN IS ANY AREA NOT STABILIZED WITH PAVEMENT, VEGETATION, MULCHING, EROSION CONTROL MATS, RIPRAP OR GRAVEL BASE ON A ROAD. LIMIT THE EXPOSED AREA TO THOSE AREAS IN WHICH WORK IS EXPECTED TO BE UNDER TAKEN DURING THE PROCEEDING 15 DAYS AND THAT CAN BE MULCHED IN ONE DAY PRIOR TO ANY SNOW EVENT. ALL AREAS SHALL BE COVERED TO BE DENUEDED UNTIL THE SUBBASE GRAVEL IS INSTALLED IN ROADWAY AREAS OR THE AREAS OF FUTURE LOAM AND SEED HAVE BEEN LOADED. SEEDED AND MULCHED HAY AND STRAW MULCH RATE SHALL BE A MINIMUM OF 150 LBS/1,000 S.F. (3 TONS/ACRE) AND SHALL BE PROPERLY ANCHORED. THE CONTRACTOR MUST TAKE THE LEAST DISTURBANCE NECESSARY TO CONTROL EROSION AND STABILIZATION FROM THE SITE. CONSTRUCTION OPERATIONS ON THE ACTUAL SITE AND WEATHER CONDITIONS. CONTINUATION OF EARTHWORK OPERATIONS ON ADDITIONAL AREAS SHALL NOT BEGIN UNTIL THE EXPOSED SOIL SURFACE ON THE AREA BEING WORKED HAS BEEN STABILIZED, IN ORDER TO MINIMIZE AREAS WITHOUT EROSION CONTROL PROTECTION.

1. SOIL STOCKPILES

STOCKPILES OF SOIL OR SUBSOIL WILL BE MULCHED FOR OVER WINTER PROTECTION WITH HAY OR STRAW AT THE NORMAL RATE OR AT 150 LBS/1,000 S.F. (3 TONS PER ACRE) OR WITH A FOUR-INCH LAYER OF WOOD WASTE EROSION CONTROL MIX. THIS WILL BE DONE WITHIN 24 HOURS OF STOCKING AND RE-ESTABLISHED PRIOR TO ANY RAINFALL OR SNOWFALL. ANY SOIL STOCKPILE WILL NOT BE PLACED (EVEN COVERED WITH HAY OR STRAW) WITHIN 100 FEET FROM ANY NATURAL RESOURCES.

2. NATURAL RESOURCES PROTECTION

ANY AREAS WITHIN 100 FEET FROM ANY NATURAL RESOURCES, IF NOT STABILIZED WITH A MINIMUM OF 75% MATURE VEGETATION CATCH, SHALL BE MULCHED BY DECEMBER 1 AND ANCHORED WITH PLASTIC NETTING OR PROTECTED WITH EROSION CONTROL MATS. DURING WINTER CONSTRUCTION, A DOUBLE LINE OF SEDIMENT BARRIERS (I.E. SILT FENCE BACKED WITH HAY BALES OR EROSION CONTROL MIX) WILL BE PLACED BETWEEN ANY NATURAL RESOURCE AND THE DISTURBED AREA.

PROJECTS CROSSING THE NATURAL RESOURCE SHALL BE PROTECTED A MINIMUM DISTANCE OF 100 FEET ON EITHER SIDE FROM THE RESOURCE. EXISTING PROJECTS NOT STABILIZED BY DECEMBER 1 SHALL BE PROTECTED WITH THE SECOND LINE OF SEDIMENT BARRIER TO ENSURE FUNCTIONALITY DURING THE SPRING THAW AND RAINS.

3. SEDIMENT BARRIERS

DURING FROZEN CONDITIONS, SEDIMENT BARRIERS SHALL CONSIST OF WOOD WASTE FILTER BERMS AS FROZEN SOIL PREVENTS THE PROPER INSTALLATION OF HAY BALES AND SEDIMENT SILT FENCES.

4. MULCHING

ALL AREA SHALL BE CONSIDERED TO BE DENUEDED UNTIL AREAS OF FUTURE LOAM AND SEED HAVE BEEN LOAMED, SEEDED AND MULCHED. HAY AND STRAW MULCH SHALL BE APPLIED AT A RATE OF 150 LB. PER 1000 SQUARE FEET OR 3 TONS/ACRE (TWICE THE NORMAL ACCEPTED RATE OF 75-LBS./1,000 S.F. OR 1.5 TONS/ACRE) AND SHALL BE PROPERLY ANCHORED. MULCH SHALL NOT BE SPREAD ON TOP OF SNOW. THE ONE-INCH DEPTH OR LESS PRIOR TO APPLICATION. AFTER EACH DAY OF FINAL GRADING, THE AREA WILL BE PROPERLY STABILIZED WITH ANCHORED HAY OR STRAW OR EROSION CONTROL MATTING. AN AREA SHALL NOT BE GRADED WITHIN SEVEN (7) DAYS OF DISTURBANCE. AREAS LOCATED WITHIN 100 FEET OF STREAMS SHALL BE ANCHORED WITH TEMPORARY EROSION CONTROL WITHIN SEVEN (7) DAYS. REFER TO WINTER EROSION CONTROL NOTES FOR THE TREATMENT OF OPEN AREAS AFTER OCTOBER 1ST OF THE CONSTRUCTION YEAR.

BETWEEN THE DATES OF SEPTEMBER 1 AND APRIL 15, ALL MULCH SHALL BE ANCHORED BY EITHER PEG LINE, MULCH NETTING, ASPHALT EMULSION CHEMICAL, TRUCK OR WOOD CELLULOSE FIBER. WHEN GROUND SURFACE IS NOT VISIBLE THROUGH THE MULCH THEN COVER IS SUFFICIENT. AFTER NOVEMBER 1ST, MULCH AND ANCHORING OF ALL BARE SOIL SHALL OCCUR AT THE END OF EACH FINAL GRADING WORK DAY.

5. MULCHING ON SLOPES AND DITCHES

SLOPES SHALL NOT BE LEFT EXPOSED FOR ANY EXTENDED TIME OF WORK SUSPENSION UNLESS FULLY MULCHED AND ANCHORED WITH PEG AND NETTING OR WITH EROSION CONTROL BLANKETS. MULCHING SHALL BE APPLIED AT A RATE OF 230 LBS/1,000 S.F. ON ALL SLOPES GREATER THAN 8%. MULCH NETTING SHALL BE USED TO ANCHOR MULCH IN ALL DRAINAGE WAYS WITH A SLOPE GREATER THAN 5% FOR SLOPES EXPOSED TO DIRECT WINDS AND FOR ALL OTHER SLOPES GREATER THAN 8%. EROSION CONTROL BLANKETS SHALL BE USED IN LIEU OF MULCH IN ALL DRAINAGE WAYS WITH SLOPES 8%. EROSION CONTROL MIX CAN BE USED TO SUBSTITUTE EROSION CONTROL BLANKETS ON ALL SLOPES EXCEPT DITCHES.

6. SEEDING

BETWEEN THE DATES OF OCTOBER 15 AND APRIL 15T, LOAM OR SEED WILL NOT BE REQUIRED. DURING PERIODS OF ABOVE FREEZING TEMPERATURES FINISHED AREAS SHALL BE FINE GRADED AND EITHER PROTECTED WITH MULCH OR TEMPORARILY SEEDED AND MULCHED UNTIL SUCH TIME AS THE FINAL TREATMENT CAN BE APPLIED. IF THE DATE IS AFTER NOVEMBER 1ST AND IF THE EXPOSED AREA HAS BEEN LOAMED, FINAL GRADED WITH A UNIFORM SURFACE

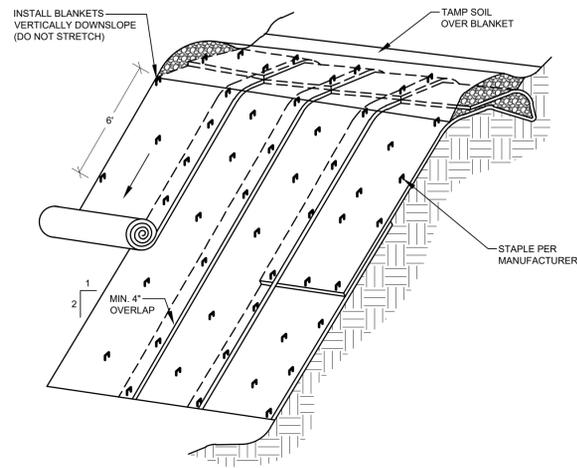

- CONSTRUCTION SPECIFICATIONS**
1. THE SOIL SURFACE SHALL BE FINELY GRADED AND SMOOTH FOR THE BLANKET TO HAVE DIRECT CONTACT WITH THE SOIL AND TO PREVENT UNDERMINING.
 2. SEED SHALL BE SOWN BEFORE INSTALLING THE EROSION CONTROL BLANKET.
 3. ALWAYS UNROLL THE BLANKET DOWNHILL WITHOUT STRETCHING AND ANCHOR THE UPSLOPE EDGE IN A 12 INCH DEEP TRENCH THAT IS BACKFILLED AND TAMPED. COVER THE TAMPED SOIL WITH BLANKET AND STAPLE TO SECURE.
 4. OVERLAP SHINGLE STYLE A MINIMUM OF 12 INCHES AT THE TOP OF EACH ROW AND 4 INCHES AT THE EDGES OF PARALLEL ROWS. ANCHOR ALONG THE OVERLAP WITH A MAXIMUM SPACING OF 3 FEET OR AS REQUIRED BY THE MANUFACTURER.

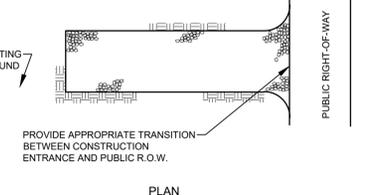
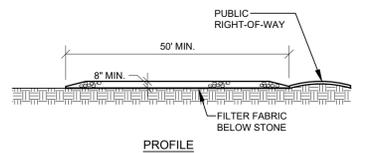
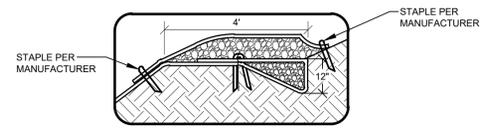

- NOTES:**
1. STONE SIZE- AASHTO DESIGNATION M43, SIZE NO. 2 (2 1/2" TO 1 1/2"). USE CRUSHED STONE.
 2. LENGTH- AS SHOWN ON PLANS, MIN. 50 FEET.
 3. THICKNESS- NOT LESS THAN EIGHT (8) INCHES.
 4. WIDTH- NOT LESS THAN FULL WIDTH OF ALL POINT OF INGRESS OR EGRESS.
 5. MAINTENANCE- THE ENTRANCE SHALL BE MAINTAINED IN A CONDITION WHICH WILL PREVENT TRACKING OR FLOWING OF SEDIMENT ONTO PUBLIC RIGHT-OF-WAY. THIS MAY REQUIRE PERIODIC TOP DRESSING WITH ADDITIONAL STONE AS CONDITIONS DEMAND AND REPAIR AND/OR CLEANOUT OF ANY MEANSURES USED TO TRAP SEDIMENT. ALL SEDIMENT SPILLED, DROPPED, WASHED OR TRACKED ONTO PUBLIC RIGHT-OF-WAY MUST BE REMOVED IMMEDIATELY.

STABILIZED CONSTRUCTION ENTRANCE
NOT TO SCALE

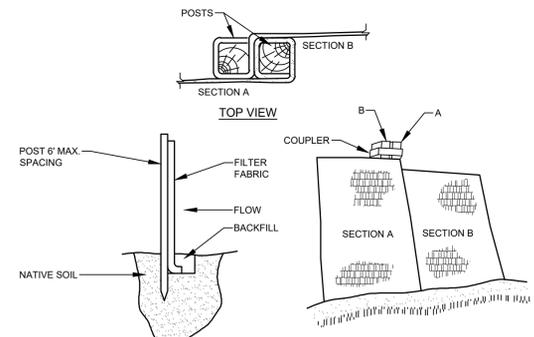

- INSTALLATION:**
1. EXCAVATE A 6" x 6" TRENCH ALONG THE LINE OF PLACEMENT FOR THE FILTER BARRIER.
 2. UNROLL A SECTION AT A TIME AND POSITION THE POSTS AGAINST THE BACK (DOWNSTREAM) WALL OF THE TRENCH.
 3. DRIVE POSTS INTO THE GROUND UNTIL APPROXIMATELY 2" OF FABRIC IS LYING ON THE TRENCH BOTTOM.
 4. LAY THE TOE-IN FLAP OF FABRIC ONTO THE UNDISTURBED BOTTOM OF THE TRENCH, BACKFILL THE TRENCH AND TAMP THE SOIL. TOE-IN CAN ALSO BE ACCOMPLISHED BY LAYING THE FABRIC FLAP ON UNDISTURBED GROUND AND PILING AND TAMPING FILL AT THE BASE, BUT MUST BE ACCOMPANIED BY AN INTERCEPTION DITCH.
 5. JOIN SECTION AS SHOWN ABOVE.
 6. BARRIER SHALL BE MIRAFI SILT FENCE OR EQUAL.
 7. THE FENCE SHOULD BE ANCHORED TO RESIST PULL-OUT AND BE STRETCHED TIGHTLY BETWEEN STAKES TO PREVENT SAGGING.
 8. IN AREAS WHERE FLAP CANNOT BE KEYS PROPERLY (DUE TO FROZEN GROUND, BEDROCK, STONY SOILS, ROOTS NEAR A PROTECTED NATURAL RESOURCE, ETC.) THE SILT FENCE SHOULD BE ANCHORED WITH AGGREGATE.
 9. FILTER BARRIER NEEDS TO BE REMOVED WHEN THE AREA IS STABILIZED.

FILTER BARRIER
NOT TO SCALE

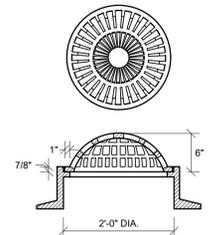

NOTES:
NEENAH FOUNDRY BR-4353 OR APPROVED EQUAL

BEEHIVE GRATE
NOT TO SCALE

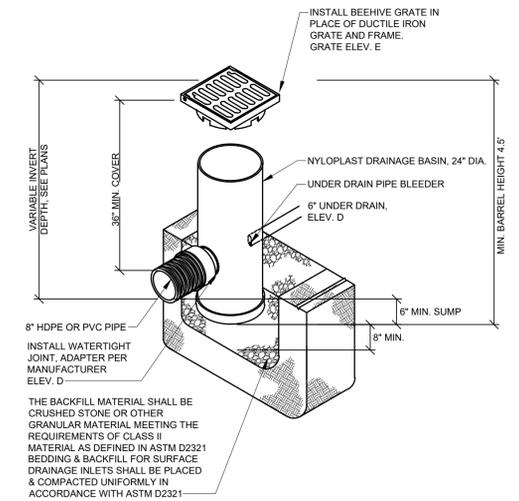

- NOTES:**
1. INSTALL BASIN IN ACCORDANCE WITH MANUFACTURER'S RECOMMENDATIONS.
 2. INSTALL BEEHIVE GRATE IN PLACE OF D.I. GRATE AND FRAME.

TYP. NYLOPLAST OUTLET CONTROL STRUCTURE
NOT TO SCALE

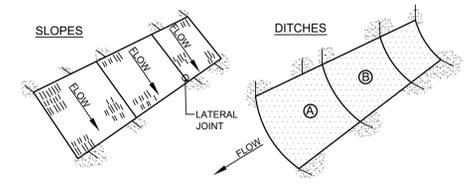

- NOTES:**
1. BURY THE TOP END OF THE MESH MATERIAL IN A 6" TRENCH AND BACKFILL AND TAMP.
 2. TRENCHING SECURE END WITH STAPLES AT 6" SPACING, 4" DOWN FROM EXPOSED END.
 3. FLOW DIRECTION JOINTS TO HAVE UPPER END OF LOWER STRIP BURIED WITH UPPER LAYERS OVERLAPPED 4" AND STAPLED. OVERLAP 6" OVER A.
 4. LATERAL JOINTS TO HAVE 4" OVERLAP OF STRIPS. STAPLE 18" ON CENTER.
 5. STAPLE OUTSIDE LATERAL EDGE 2" ON CENTER.
 6. WIRE STAPLES TO BE MIN OF #11 WIRE 6" LONG AND 1-1/2" WIDE.
 7. USE NORTH AMERICAN GREEN DS 150 OR APPROVED EQUAL.

EROSION CONTROL BLANKET
NOT TO SCALE

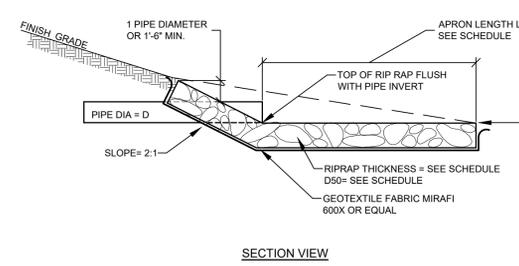
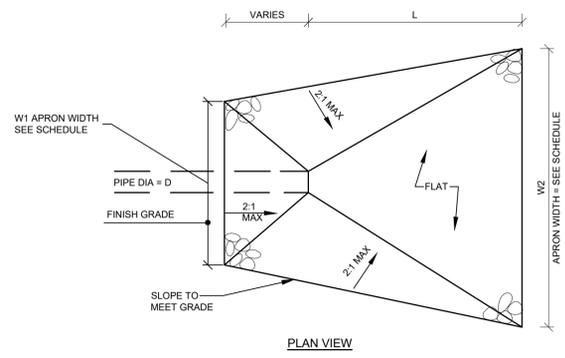

NOTES:

1. RIPRAP TO BE PROCESSED ANGULAR ROCK.
2. RIPRAP GRADATION SHALL BE A WELL GRADED MIX FROM ABOUT 1.5 TIMES D SIZE TO 25 PERCENT OF THE D SIZE.
3. THE RIPRAP STONES SHALL BE CAREFULLY PLACED FROM THE TOE OF THE SLOPE UPWARD. STONES SHALL BE LOWERED TO THE SLOPE AND NOT BE ALLOWED TO DROP MORE THAN 12" ONTO THE GEOTEXTILE.
4. THE FINISHED SURFACE SHALL BE A RELATIVELY SMOOTH, UNIFORMLY SLOPED SURFACE.

TYPICAL RIPRAP APRON SCHEDULE

CULVERT DIAMETER - D (IN.)	APRON LENGTH - L (FT.)	WIDTH - W1 (FT.)	WIDTH - W2 (FT.)	RIPRAP D50 (IN.)	RIPRAP THICKNESS (IN.)
12	8	3	9	6	14
15	10	4	12	6	14
18	13	5	15	7	16
24	18	6	20	8	18
36	29	9	32	11	25
42	33	11	37	12	27
48	39	12	43	16	36

RIPRAP APRON
NOT TO SCALE

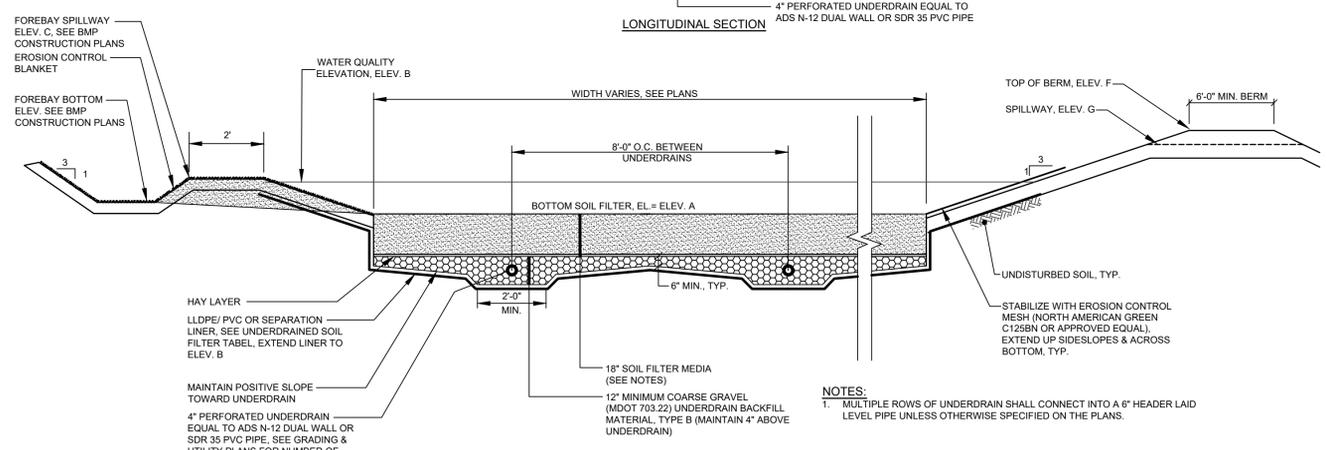

- NOTES:**
1. MULTIPLE ROWS OF UNDERDRAIN SHALL CONNECT INTO A 6" HEADER LAID LEVEL PIPE UNLESS OTHERWISE SPECIFIED ON THE PLANS.

UNDERDRAINED SOIL FILTER DETAIL
NOT TO SCALE

UNDERDRAINED SOIL FILTER TABLE

UNDERDRAINED SOIL FILTER #	ELEV. A	ELEV. B	ELEV. C	ELEV. D	ELEV. E	ELEV. F	ELEV. G	CONTROL STRUCTURE	UNDER DRAIN PIPE BLEEDER SIZE	LINER TYPE
1	269.0'	269.81'	270.50'	266.80'	270.70'	272.70'	271.5'	CS-1	1.4" DIA.	30 MIL HDPE/PVC
2	269.0'	269.65'	270.50'	266.80'	270.85'	272.10'	271.0'	CS-2	1.2" DIA.	30 MIL HDPE/PVC

UNDERDRAINED SOIL FILTER CONSTRUCTION OVERSIGHT NOTES:
THE APPLICANT WILL RETAIN THE SERVICES OF A PROFESSIONAL ENGINEER TO INSPECT THE CONSTRUCTION AND STABILIZATION OF THE UNDERDRAIN. IF NECESSARY, THE INSPECTING ENGINEER WILL INTERPRET THE UNDERDRAIN CONSTRUCTION PLAN FOR THE CONTRACTOR. ONCE ALL STORMWATER MANAGEMENT STRUCTURES ARE CONSTRUCTED AND STABILIZED, THE INSPECTING ENGINEER WILL NOTIFY THE CITY PUBLIC WORKS DEPARTMENT IN WRITING WITHIN 30 DAYS TO STATE THAT THE POND HAS BEEN COMPLETED. ACCOMPANYING THE ENGINEER'S NOTIFICATION MUST BE A LOG OF THE ENGINEER'S INSPECTIONS GIVING THE DATE OF EACH INSPECTION, THE TIME OF EACH INSPECTION, AND THE ITEMS INSPECTED ON EACH VISIT, AND INCLUDE ANY TESTING DATA OR SIEVE ANALYSIS DATA OF EVERY MINERAL SOIL AND SOIL MEDIA SPECIFIED IN THE PLANS AND USED ON SITE.

- CONSTRUCTION SEQUENCE:** THE UNDERDRAIN AND VEGETATION MUST NOT BE INSTALLED UNTIL THE AREA THAT DRAINS TO THE UNDERDRAIN HAS BEEN PERMANENTLY STABILIZED WITH PAVEMENT OR OTHER STRUCTURE. 90% VEGETATION COVER, OR OTHER PERMANENT STABILIZATION UNLESS THE RUNOFF FROM THE CONTRIBUTING DRAINAGE AREA IS DIVERTED AROUND THE FILTER UNTIL STABILIZATION IS COMPLETED.
1. **COMPACTION OF UNDERDRAIN:** UNDERDRAIN BEDDING MATERIAL MUST BE COMPACTED TO BETWEEN 90% AND 92% STANDARD PROCTOR. THE BED SHOULD BE INSTALLED IN AT LEAST 2 LIFTS OF 8 INCHES TO PREVENT POCKETS OF LOOSE MEDIA.
 2. **CONSTRUCTION OVERSIGHT:** INSPECTION BY A PROFESSIONAL ENGINEER WILL OCCUR AT A MINIMUM:
 - A. FOR FIRST UNDERDRAIN CONSTRUCTED, AFTER UNDERDRAIN PIPE IS INSTALLED AT GRADE AND BUT NOT BACKFILLED, AFTER THE UNDERDRAIN PIPE IS COMPLETELY BACKFILLED AND BEFORE PLACEMENT OF SOIL FILTER MEDIA.
 - B. AFTER THE SOIL FILTER MEDIA HAS BEEN INSTALLED.
 - C. AFTER ONE YEAR TO INSPECT HEALTH OF THE VEGETATION AND MAKE CORRECTIONS.
 - D. ALL MATERIAL USED FOR THE CONSTRUCTION OF THE UNDERDRAIN MUST BE CONFIRMED AS SUITABLE BY THE DESIGN ENGINEER. TESTING MUST BE DONE BY A CERTIFIED LABORATORY.
- TESTING AND SUBMITTALS**
1. THE SOIL FILTER MEDIA SHALL CONSIST OF A BLEND OF MATERIALS AS IDENTIFIED IN THE UNDERDRAINED SOIL FILTER MEDIA NOTES BELOW. THE CONTRACTOR SHALL IDENTIFY THE LOCATION OF THE SOURCE FOR EACH COMPONENT OF THE UNDERDRAIN AND SUBMIT GRADATIONS FOR THE UNDERDRAIN MATERIALS TO THE ENGINEER FOR APPROVAL. SAMPLES MUST BE A COMPOSITE OF THREE DIFFERENT LOCATIONS (GRABS) FROM THE STOCKPILE OR PIT FACE. SAMPLE SIZE REQUIRED WILL BE DETERMINED BY THE TESTING LABORATORY.

- UNDERDRAINED SOIL FILTER MEDIA NOTES:**
1. SOIL FILTER MEDIA CONSISTS OF A SILTY SAND SOIL OR SOIL MIXTURE COMBINED WITH A MATURE, MODERATELY FINE SHREDDED BARK OR WOOD FIBER MIX 20% TO 25% BY VOLUME (NO LESS THAN 10% BY DRY WEIGHT). THE RESULTING MIXTURE SHOULD HAVE 8% TO 12% PASSING THE NO. 200 SIEVE AND A CLAY CONTENT OF LESS THAN 2%. THE PROPORTIONS OF THE MIXTURE CAN BE ADJUSTED SO IT WILL CONTAIN SUFFICIENT FINES AND ORGANIC MATTER. THE SOIL FILTER MEDIA MAY CONTAIN THE FOLLOWING (BY VOLUME):
 - A. 50% OF SAND (MAINE DOT SPECIFICATION #703.01 IS CLOSE BUT IT CONTAINS INSUFFICIENT FINE MATERIAL FOR THE FILTER MEDIA).
 - B. 20% OF SANDY LOAM TO FINE SANDY LOAM (TABLE 7.1.2).
 - C. 30% OF MATURE COMPOSTED WOODY FIBERS AND FINE SHREDDED BARK, SUPERHUMUS OR EQUIVALENT (ADJUSTED FOR MINERAL SOIL CONTENT).
 2. MATERIAL LAYERS ABOVE THE UNDERDRAIN BACKFILL LAYER SHALL BE A UNIFORM MIX, FREE OF STONES, STUMPS, ROOTS, OR OTHER SIMILAR OBJECTS LARGER THAN TWO INCHES. NO OTHER MATERIALS OR SUBSTANCES THAT MAY BE HARMFUL TO PLANT GROWTH, OR PROVE A HINDRANCE TO THE PLANTING OR MAINTENANCE OPERATIONS CAN BE MIXED WITHIN THE FILTER. DURING CONSTRUCTION, CARE SHOULD BE TAKEN TO AVOID COMPACTION OF BOTH THE GRAVEL AND SOIL FILTER.
 3. OVER COMPACTION OF UNDERDRAIN MATERIAL SHALL BE AVOIDED. IF OVER COMPACTION OCCURS, ROTOTILL AGAIN PRIOR TO SEEDING OR SODDING.

ROBERT A. WINSORLEY, PE 6888



REV.	BY	DATE	STATUS
1	MM/E	9/14/22	REVISED PER TOWN OF RAYMOND COMMENTS
2	MM/E	7/12/21	REVISED PER REVIEW COMMENTS
3	MM/E	6/29/21	RELEASED FOR CLIENT REVIEW

THIS PLAN SHALL NOT BE MODIFIED WITHOUT WRITTEN PERMISSION FROM SEBAGO TECHNIQS, INC. ANY ALTERATIONS, AUTHORIZED OR OTHERWISE, SHALL BE AT THE USER'S SOLE RISK AND WITHOUT LIABILITY TO SEBAGO TECHNIQS, INC.

SEBAGO TECHNIQS
WWW.SEAGOTECHNIQS.COM
75 John Roberts Rd.
Sullivan, ME 04106
Tel. 207-200-2100

DETAILS OF:
JORDAN BAY MARINA
1328 ROOSEVELT TRAIL
RAYMOND, ME

FOR:
PORT HARBOR MARINE
1 SPRING POINT DRIVE
SOUTH PORTLAND, ME 04106

DESIGNED	JSH
DRAWN	DAB
CHECKED	RAM
DATE	06/22/22
SCALE	NTS
PROJECT	14265-02

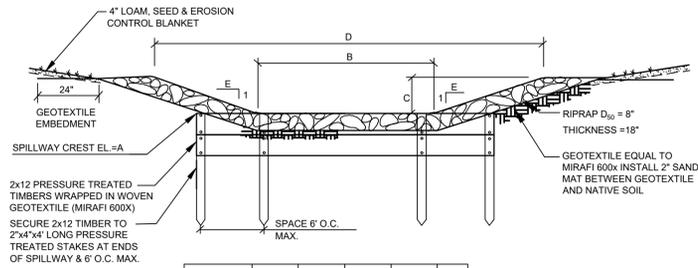

SPILLWAY	A	B	C	D	E
UDSF-1	271.5'	12.5'	0.5'	15.5'	3'
UDSF-2	271.0'	10.0'	1.0'	16'	3'

SPILLWAY CROSS-SECTION
NOT TO SCALE

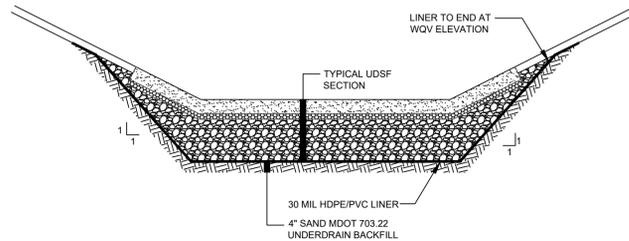

HDPE/PVC LINER DETAIL
NOT TO SCALE

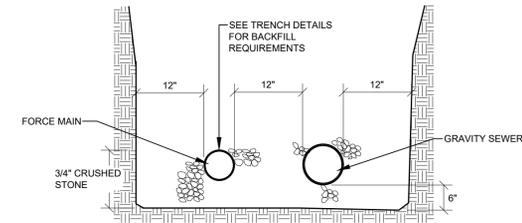

TWO PIPE TRENCH
NOT TO SCALE

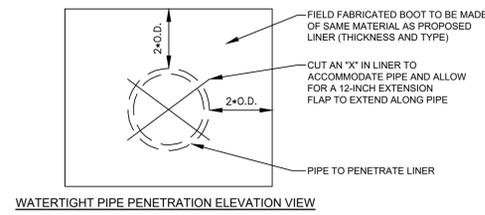

WATERTIGHT PIPE PENETRATION ELEVATION VIEW

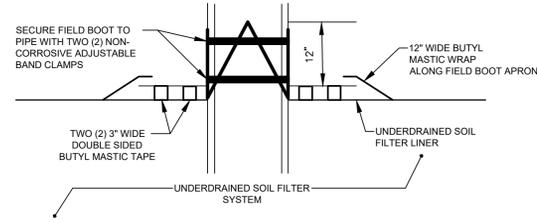

WATERTIGHT PIPE PENETRATION
NOT TO SCALE

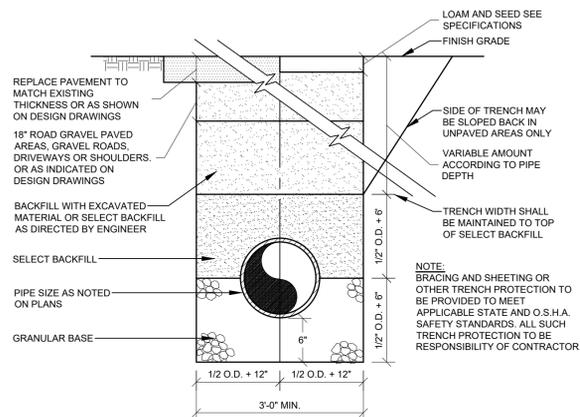

TRENCH SECTION
NOT TO SCALE

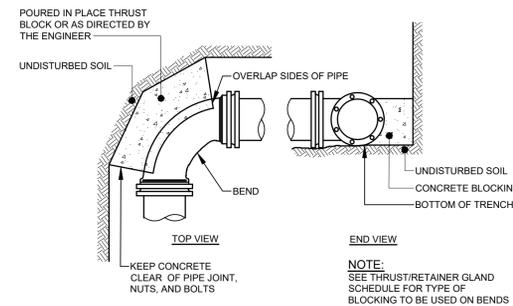

STANDARD BEND BLOCKING
NOT TO SCALE

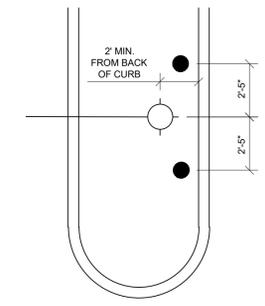

FIRE HYDRANT LOCATION
NOT TO SCALE

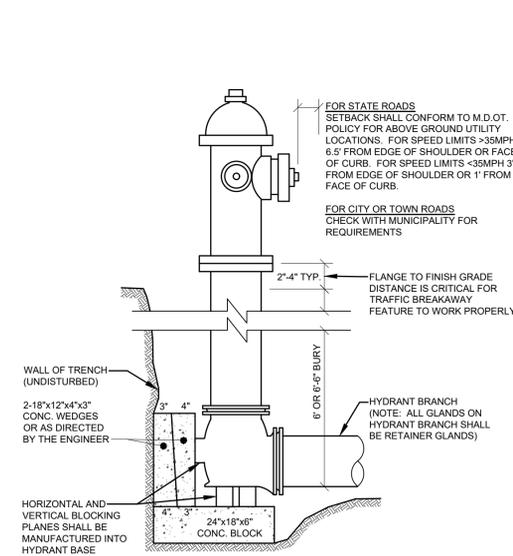

HYDRANT INSTALLATION
NOT TO SCALE

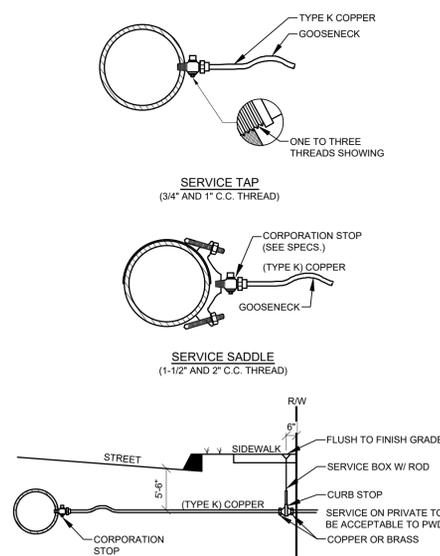

SERVICE CONNECTION
NOT TO SCALE

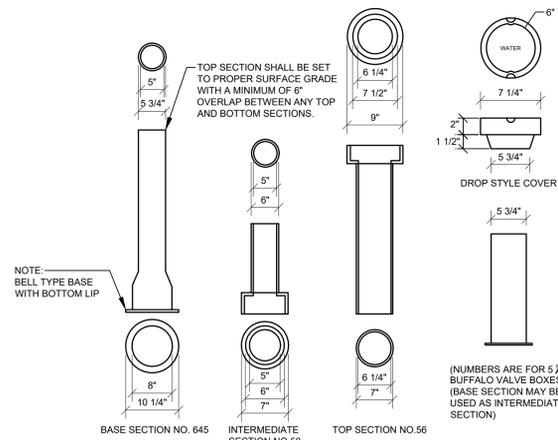

VALVE BOX & COVER
NOT TO SCALE

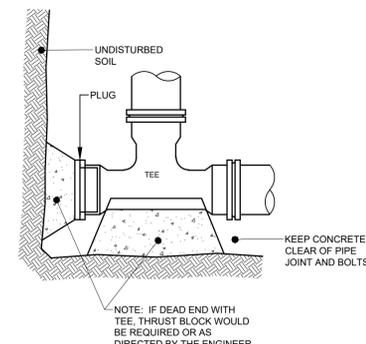

STANDARD TEE BLOCKING
NOT TO SCALE

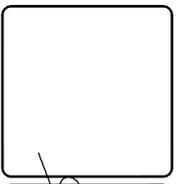

REVISIONS

NO.	DATE	BY	REASON
C	9/14/22	MME	REVISED PER TOWN OF RAYMOND COMMENTS
B	7/12/21	MME	REVISED PER REVIEW COMMENTS
A	6/29/21	MME	RELEASED FOR CLIENT REVIEW

STATUS: _____
DATE: _____

THIS PLAN SHALL NOT BE MODIFIED WITHOUT WRITTEN PERMISSION FROM SEBAGO TECHNIQS, INC. ANY ALTERATIONS, AUTHORIZED OR OTHERWISE, SHALL BE AT THE USER'S SOLE RISK AND WITHOUT LIABILITY TO SEBAGO TECHNIQS, INC.



DETAILS
OF: **JORDAN BAY MARINA**
1328 ROOSEVELT TRAIL
RAYMOND, ME
FOR: **PORT HARBOR MARINE**
1 SPRING POINT DRIVE
SOUTH PORTLAND, ME 04106

DESIGNED	JSH
DRAWN	DAB
CHECKED	RAM
DATE	06/22/22
SCALE	NTS
PROJECT	14265-02

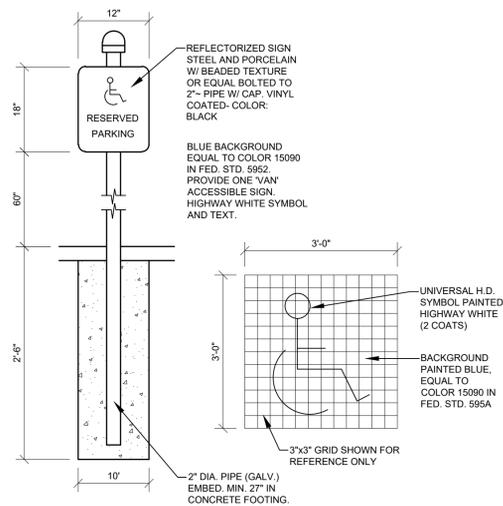

ADA ACCESSIBLE SIGNS
NOT TO SCALE

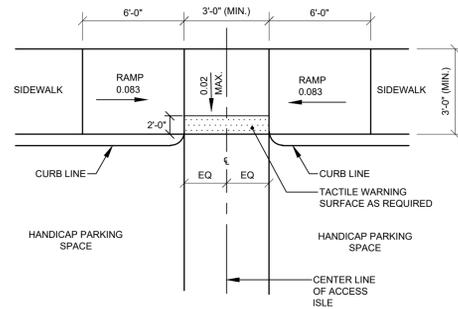

ADA ACCESSIBLE RAMP
NOT TO SCALE

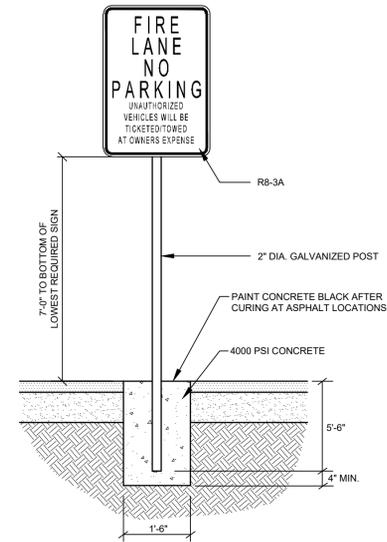

FIRE LANE SIGN
NOT TO SCALE

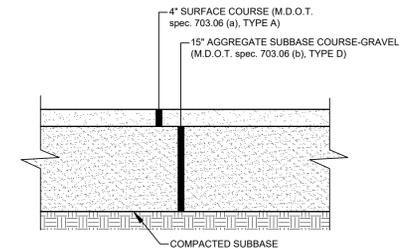

GRAVEL PARKING AREA
NOT TO SCALE

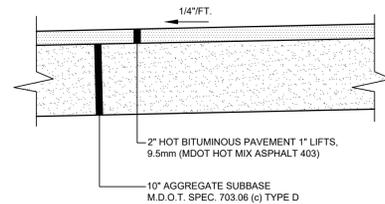

BITUMINOUS SIDEWALK
NOT TO SCALE

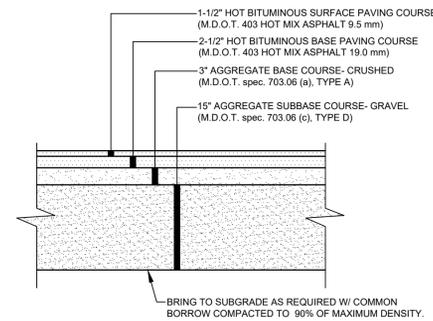

- NOTES:**
1. COMPACT GRAVEL SUBBASE, BASE COURSE TO 92% OF MAXIMUM DENSITY USING HEAVY ROLLER COMPACTION.
 2. CONTRACTOR SHALL SET GRADE STAKES MARKING SUBBASE AND FINISH GRADE ELEVATIONS FOR CONSTRUCTION REFERENCE.
 3. CONTRACTOR MAY REPLACE BITUMINOUS PAVING SECTION WITH TWO (2) 1-3/4" LIFTS OF 12.5mm SUPERPAVE MIX. SUBMIT PAVEMENT MIX DESIGN PRIOR TO CONSTRUCTION.

PAVED PARKING LOT SECTION
NOT TO SCALE

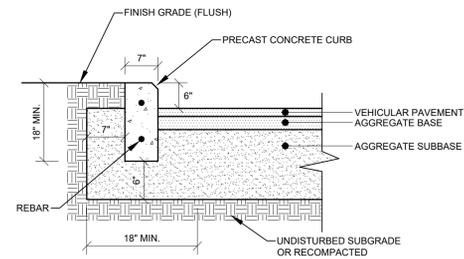

PRECAST CONCRETE CURB
NOT TO SCALE

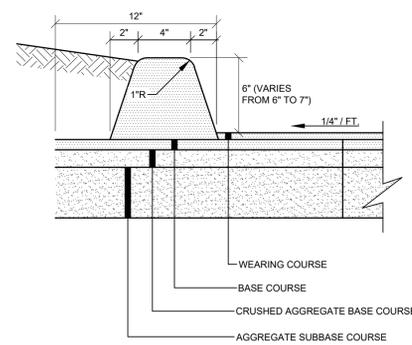

MOLD 1

BITUMINOUS CURB SECTION
NOT TO SCALE

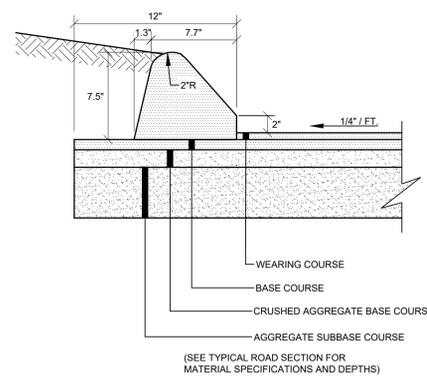

MOLD 2

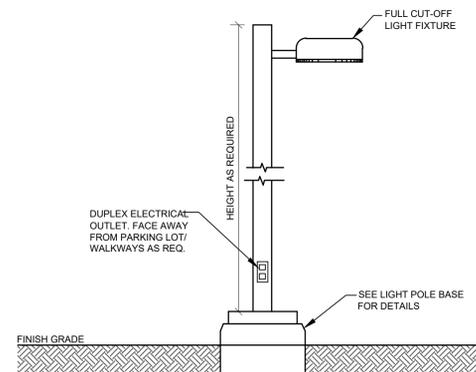

POLE MOUNTED LIGHT FIXTURE
NOT TO SCALE

NOTE: LIGHTS SHALL BE SHIELDED AND EMIT NO MORE THAN 1.0 FOOT-CANDLES AT PROPERTY LINE

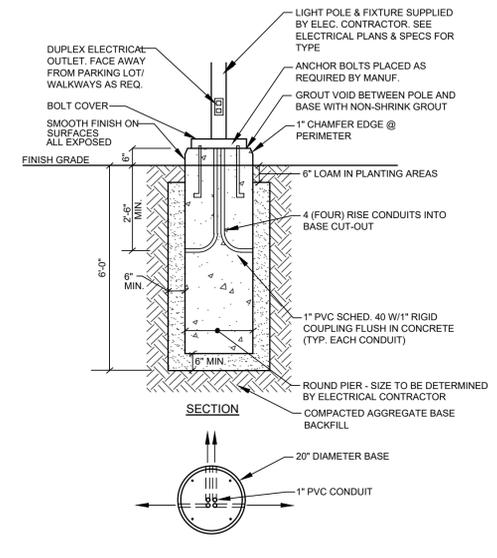

- NOTES:**
1. CONCRETE $f_c=5000$ psi @ 28 DAYS WITH STEEL REINFORCEMENT
 2. CONDUIT AND ANCHOR BOLTS PLACED AS REQUIRED PROVIDED BY ELECTRICAL CONTRACTOR
 3. PROVIDE 2 COATS BITUMINOUS DAMPROOFING FOR ALL CONCRETE BELOW GRADE
 4. INSTALL BASE 3'-0" ABOVE FINISH GRADE IN LOCATIONS WHERE POLES ARE IN PARKING LOT PAVEMENT.
 5. LIGHT POLE BASE AS MANUFACTURED BY SUPERIOR CONCRETE OR APPROVED EQUAL.

20" ROUND LIGHT POLE BASE
NOT TO SCALE



REV.	BY	DATE	STATUS
C	MM/E	9/14/22	REVISED PER TOWN OF RAYMOND COMMENTS
B	MM/E	7/12/21	REVISED PER REVIEW COMMENTS
A	MM/E	6/29/21	RELEASED FOR CLIENT REVIEW

THIS PLAN SHALL NOT BE MODIFIED WITHOUT WRITTEN PERMISSION FROM SEBAGO TECHNICS, INC. ANY ALTERATIONS, AUTHORIZED OR OTHERWISE, SHALL BE AT THE USER'S SOLE RISK AND WITHOUT LIABILITY TO SEBAGO TECHNICS, INC.



DETAILS

OF: **JORDAN BAY MARINA**
1328 ROOSEVELT TRAIL
RAYMOND, ME

FOR: **PORT HARBOR MARINE**
1 SPRING POINT DRIVE
SOUTH PORTLAND, ME 04106

DESIGNED	JSH
DRAWN	DAB
CHECKED	RAM
DATE	06/22/22
SCALE	NTS
PROJECT	14265-02



EXISTING CONDITIONS LEGEND

- WATERSHED BOUNDARY
- TIME OF CONCENTRATION
- REACH
- CATCHMENT AREA
- REACH
- POINT OF ANALYSIS
- STORMWATER TREATMENT/DETENTION POND
- HSG #
- HSG #

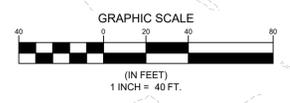

REV	BY	DATE	STATUS
C	MWE	9/14/22	REVISED PER TOWN OF RAYMOND COMMENTS
B	MWE	7/12/21	REVISED PER REVIEW COMMENTS
A	MWE	6/29/21	RELEASED FOR CLIENT REVIEW

THIS PLAN SHALL NOT BE MODIFIED WITHOUT WRITTEN PERMISSION FROM SEBAGO TECHNICS, INC. ANY ALTERATIONS, AUTHORIZED OR OTHERWISE, SHALL BE AT THE USER'S SOLE RISK AND WITHOUT LIABILITY TO SEBAGO TECHNICS, INC.

SEBAGO
TECHNICS
WWW.SEBAGOTECHNICS.COM
75 John Roberts Rd.
Sullivan, ME 04106
South Portland, ME 04106
Tel. 207-250-2100

EXISTING CONDITIONS - SWP
OF:
JORDAN BAY MARINA
1328 ROOSEVELT TRAIL
RAYMOND, ME
FOR:
PORT HARBOR MARINE
1 SPRING POINT DRIVE
SOUTH PORTLAND, ME 04106

DESIGNED	JSH
DRAWN	DAB
CHECKED	RAM
DATE	06/22/22
SCALE	1" = 30'
PROJECT	14265-02



PROPOSED CONDITIONS LEGEND

- WATERSHED BOUNDARY
- TIME OF CONCENTRATION
- REACH
- SUBCATCHMENT LABEL
- REACH
- POINT OF ANALYSIS
- STORMWATER TREATMENT/DETENTION POND
- SOILS BOUNDARY
- SOILS BOUNDARY

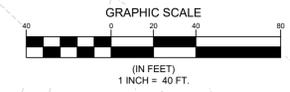

ROBERT A. MANSORLEY, P.E. 6888

C	MWE	9/14/22	REVISED PER TOWN OF RAYMOND COMMENTS
B	MWE	7/12/21	REVISED PER REVIEW COMMENTS
A	MWE	6/29/21	RELEASED FOR CLIENT REVIEW
REV	BY	DATE	STATUS

THIS PLAN SHALL NOT BE MODIFIED WITHOUT WRITTEN PERMISSION FROM SEBAGO TECHNICS, INC. ANY ALTERATIONS, AUTHORIZED OR OTHERWISE, SHALL BE AT THE USER'S SOLE RISK AND WITHOUT LIABILITY TO SEBAGO TECHNICS, INC.

SEBAGO
TECHNICS
WWW.SEBAGOTECHNICS.COM

75 John Roberts Rd.
Sullivan A4
South Portland, ME 04106
Tel. 207-200-2100

PROPOSED CONDITIONS - SWP
OF:
JORDAN BAY MARINA
1328 ROOSEVELT TRAIL
RAYMOND, ME
FOR:
PORT HARBOR MARINE
1 SPRING POINT DRIVE
SOUTH PORTLAND, ME 04106

DESIGNED	JSH
DRAWN	DAB
CHECKED	RAM
DATE	06/22/22
SCALE	1" = 30'
PROJECT	14265-02