



**BOARD OF SELECTMEN  
Minutes**

June 20, 2017

6:30pm – Regular Meeting

Broadcast Studio  
423 Webbs Mills Road

*Resolution: We, the Raymond Board of Selectmen, recognize our individual and collective responsibilities as leaders and representatives of our community. To this end, we pledge to conduct ourselves in a manner befitting these roles and duties. We pledge and encourage others to "Be the Influence" and to recognize that decisions matter.*

**Selectmen in attendance:** Joe Bruno, Samuel Gifford, Teresa Sadak, and Rolf Olsen

**Selectmen absent:** Lawrence Taylor

**Town Staff in attendance:**

Don Willard – Town Manager  
Chris Hanson – Code Enforcement Officer  
Sue Carr – Tax Collector  
Sue Look – Town Clerk

1) **Called to order** at 6:30pm by Chairman Bruno.

2) **Election of Chair, Vice Chair, and Parliamentarian** – Board of Selectmen

**Motion** to nominate Teresa Sadak as Chair by Selectman Bruno. Seconded by Selectman Gifford.

**Nominations declared closed** by Selectman Bruno. Seconded by Selectman Olsen.

**Unanimously approved.**

**Motion** to nominate Rolf Olsen as Vice-Chair by Selectman Bruno. Seconded by Selectman Gifford.

**Nominations declared closed** by Selectman Bruno. Seconded by Chairman Sadak.

**Unanimously approved.**

**Motion** to nominate Joe Bruno as Parliamentarian by Selectman Olsen. Seconded by Selectman Gifford.

**Nominations declared closed** by Chairman Sadak. Seconded by Selectman Bruno.

**Unanimously approved.**

### 3) Minutes of previous meetings

- a) May 9, 2017 Selectmen Meeting Minutes – Regular Meeting
- b) May 18, 2017 Special Selectmen Meeting Minutes – Insurance RFP

**Motion** to approve as presented by Selectman Gifford. Seconded by Selectman Olsen.

**Unanimously approved.**

### 4) New Business

- a) Consideration of Issuing a Peddler's License – Chris Hanson, Code Enforcement Officer

Jose Chavez Mendoza has requested a Peddler's License to open a temporary food trailer for A La Mexicana while the restaurant is being rebuilt.

CEO Hanson – This is the first Peddler's License we have issued for a while. It is for A La Mexicana. After the restaurant burned they approached me to open a food cart in front of the restaurant and potentially using their picnic tables for outside use. The plans presented may change depending on whether or not the restaurant building will be torn down. If the building is to be torn down, they will fence in the area and the location of the cart will need to be adjusted. As I condition I recommend that I have the final say of exactly where it goes. The Fire Department and I make sure it is safe for the public. The other condition is that they get their State Food Service License. The carts come all set up, but the State will do a site visit to make sure that water and septic are all set.

Chairman Sadak – Is the building pretty much damaged? Would you like to answer questions Mr Chavez?

Mr Chavez – Yes, the building is damaged.

Chairman Sadak – What requirements does Raymond have for the Peddler's License?

Selectman Bruno – A food truck. Are we talking a food truck or a trailer...?

Mr Chavez – A trailer.

Selectman Bruno – A trailer. So, it is going to stick out in the parking lot? How far?

CEO Hanson – He was talking about 18'. They have plenty of parking in the front to accommodate that. We want to make sure that they have the aisle width to make it safe. They may need to add some barricades to keep people out of there. That is why I said it would be up to the Fire Department and the Codes Officer to determine the final location. Where they originally wanted it was right up against the entrance to the building. The problem they have is they may need to tear the building down, which would mean adding fencing around the building and moving the trailer forward.

Selectman Bruno – What about traffic flow? Isn't there an entrance right there?

CEO Hanson – That is why I said we needed to approve the final plans. There is parking at that entrance, there is parking in the rear against the building. We will locate them depending on what they do with the building. I think the main goal was to keep them in business doing something.

Selectman Bruno – Yes. That is our goal too. I am concerned about pedestrians...

Chairman Sadak – Yes.

CEO Hanson – We may need to have them put up some Jersey Barriers to keep them safe.

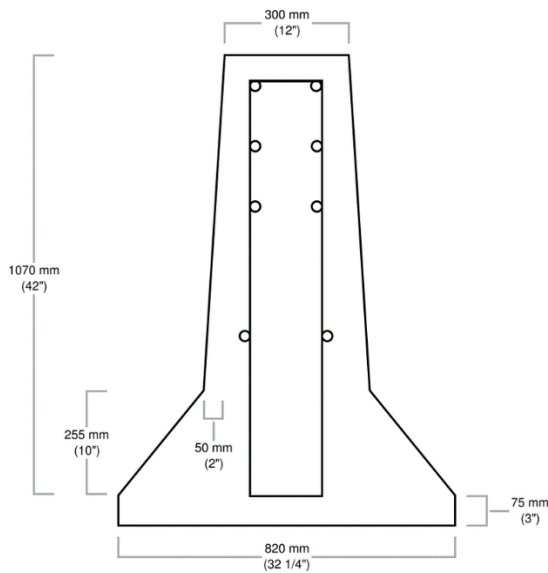

*42-inch-high variation of the Jersey barrier known as an Ontario Tall Wall, used to deflect vehicles from crossing into the opposing lanes of traffic.*

Selectman Bruno – Is there still an empty lot next to that building?

CEO Hanson – No, that is where the septic system is. That may be where the cart will go, it depends on where they put the fence.

Chairman Sadak – Is it a possibility to block that one entrance from 302 since there are multiple entrances?

CEO Hanson – Those are all controlled by MDOT. It would take a pretty big effort to close those down.

Selectman Olsen – Timing-wise what are you looking at?

Mr Chavez – We just ordered the trailer, so I do not know.

Selectman Gifford – If you are approved this evening, then what?

Mr Chavez – I need to get the State Food Service License.

CEO Hanson – Getting the cart is going to be the problem. I have talked to the owners and the cart will have fire suppression. I believe the insurance company is paying for it, so they will be cutting a check. My guess is about 2 weeks. If it can happen faster than that we will work with them.

Selectman Bruno – Is this a temporary situation or will it be permanent?

CEO Hanson – Temporary. The Peddler's License is good for 90 days and the Select Board can grant extensions.

**Motion** to approve as presented by Selectman Bruno. Seconded by Selectman Gifford.

**Unanimously approved.**

b) Resignation of Robert O'Neill from Planning Board – Don Willard, Town Manager

Town Manager Willard – Long time Planning Board member. He served 13 years and

has been Chair for a number of years. He has been an exemplary, exceptional leader of the Planning Board, leading the board through some difficult issues always with professionalism in a thorough and fair manner. We hate to see him go, but he has some things he wants to do in his life. He did express in his letter of resignation that he hopes to come back at some point for future service to the town. I think we should encourage that and send him a nice letter of thanks for his service. He is an exceptional volunteer.

**Motion** to accept by Selectman Olsen. Seconded by Selectman Bruno.

**Unanimously approved.**

c) Consideration of Appointing Danielle Stumper to the Planning Board

Ms Stumper – Raymond resident looking to join the Planning Board. I am a Raymond native. I have moved back after living in Virginia for about 10 years. I love Raymond and as soon as my husband and I had children I said we are moving home. I am looking to support the town and community by volunteering my time. I am a mortgage broker in Windham and I think my ability with Real Estate and to remain neutral will be a benefit.

Selectman Gifford – Do you have a knowledge of the requirements for a Planning Board member? For example, Shoreline...?

Ms Stumper – Shoreline, no. What specific requirements?

Chairman Sadak – I didn't know anything about being a Selectman and I am up here, so don't let that dissuade you.

Ms Stumper – I am eager to learn if you are willing to bear with me. I am certainly willing to put in the effort. I have been in lending for 10 years for both residential and commercial.

CEO Hanson – To be fair, I think that most of our Planning Board members, when they start, have very little knowledge of our ordinances.

Chairman Sadak – One thing I have found is that the boards are that they are patient and will work with you.

Sheila Bourque – There is also a 1 day training class that the Town makes available.

**Motion** to appoint by Selectman Gifford. Seconded by Selectman Bruno.

**Unanimously approved.**

d) Consideration of Appointing Patricia Beaton to the Zoning Board of Appeals

Ms Beaton – Raymond resident, live down here off Raymond Hill Road. I have a background with Real Estate, research and development, and I am on the Planning Board. The 1 day course was fabulous. It covered everything.

Chairman Sadak – Can people be on both the Planning Board and the Zoning Board of Appeals?

CEO Hanson – Yes. The ZBA hears appeals of the CEO, not the Planning Board. Appeals from the Planning Board would go to superior court.

**Motion** to appoint by Selectman Bruno. Seconded by Selectman Gifford.

**Unanimously approved.**

- e) Tax Acquired Properties, Quit Claim Deeds – Sue Carr, Tax Collector

**Motion** to grant the Quit Claim Deed for Map 10 Lot 124 to Martha Murray by Selectman Bruno. Seconded by Selectman Gifford.

Tax Collector Carr – This is a property that Ms Murray has been paying on and is finally caught up.

**Unanimously approved.**

**Motion** to grant the Quit Claim Deed for Map 21 Lot 2 on Notched Pond Road to Martin and Cynthia Barry by Selectman Bruno. Seconded by Selectman Gifford.

Town Manager Willard – This is the property we are selling thought a Real Estate agent. Once the Quit Claim Deed is signed and filed, I will execute the remaining paper work to complete the transaction.

Selectman Bruno – How much are we selling it for?

Town Manager Willard - \$14,100, which is better than we would have done on a sealed bid.

**Unanimously approved.**

Chairman Sadak – Sue, how is that list coming?

Tax Collector Carr – It is getting down. I only had 1 foreclosure in February and they came in a paid the taxes. There are a couple who keep telling me that they are going to sell. They said this past winter that they intended to try to sell in the spring.

- f) Authorization of Town Manager to Sign Agreement for Locally Administered Federal Aid Main Street Sidewalk Project with MDOT – Don Willard, Town Manager

**Motion** to authorize the Town Manager to sign the agreements for the locally administered Federal-aid Main Street Sidewalk Project with MDOT by Selectman Bruno. Seconded by Selectman Olsen.

**Unanimously approved.**

- g) Consideration of FY 2017-18 Fee Schedule – Sue Look, Town Clerk

Selectman Bruno – 1.5% is available and Cathy should look into other options at local banks. Using your credit card at the town office is overpriced.

**Motion** to accept the presented as the maximum rates and if we are able to reduce the costs we will go with the lower rates by Selectman Bruno. Seconded by Selectman Olsen.

**Unanimously approved.**

h) Consideration of FY 2017-18 Committee Appointments – Sue Look, Town Clerk

**Motion** to appoint as presented by Selectman Bruno. Seconded by Selectman Gifford.

Selectman Olsen – Thanks to all of the volunteers who have stepped up to serve.

**Unanimously approved.**

i) Consideration of FY 2017-18 Staff Appointments – Sue Look, Town Clerk

**Motion** to appoint as presented by Selectman Gifford. Seconded by Selectman Olsen.

**Unanimously approved.**

**5) Public Comment**

Beth Clark – Irene Morris – Chase Rand – representing Aging Friendly Community. We represent about 40 residents. We would like the support of the town to join AARP and the World Health Network to move forward with this effort. We would like the Town Manager to sign the AARP application on behalf of the Town. This is just the first step in the stage. We have a meeting this Thursday at 3pm at the Public Safety building.

Selectman Gifford – I think this is a good idea.

Selectman Bruno – I just want to note that it is not that we do not support your efforts, but we can not make a decision on this as it is in the Public Comment section of the meeting. We will be supportive, but we can not formally do it tonight.

**6) Selectman Comment**

Selectman Olsen – Based on the Election Results we need to look at where we need to make changes to our current Town Office.

Selectman Bruno – I think Don, Chris, and Nathan need to get a list of what needs to be fixed.

Chairman Sadak – Welcome back Sam and Lonnie.

Frank McDermott – I would like to see other options presented for the Town Office, including the Library and/or a Community Center.

Irene Morris – People did not understand the question. Some were very sorry that they voted no once they realized that it could include the Library and a recreation center.

**7) Town Manager's Report and Communications**

a) Confirm Dates for Upcoming Regular Meetings

- September 12, 2017

b) Reminder of Upcoming Holiday Schedule

- Tuesday, July 4, 2017 – in observance of Independence Day
- Monday, September 4, 2017 – in observance of Labor Day

A few weeks ago, Windham Town Manager Tony Plant asked if we would have interest

in joining Windham, Standish, and Gorham in an LED street light conversion project. They are putting together an RFP to see what might be possible and to see cost structure toward self-sufficiency.

#### 8) Treasurer's Warrant

**Motion** to approved the Treasurer's Warrant dated June 20, 2017 for a total of \$101,479.97 by Selectman Bruno. Seconded by Selectman Gifford.

**Unanimously approved.**

#### 9) Executive Session

- a) Town Manager's Annual Performance Review (Pursuant to MRSA 1 §405 (6)(A))

**Motion** to enter Executive Session as noted above at 7:08pm by Selectman Bruno. Seconded by Selectman Olsen.

**Unanimously approved.**

**Motion** to leave Executive Session at 8:21pm by Selectman Gifford. Seconded by Selectman Olsen.

**Unanimously approved.**

**Motion** to grant our Town Manager a \$1,000 raise and to extend an extra year on his contract by Selectman Bruno. Seconded by Selectman Gifford.

**Unanimously approved.**

#### 10) Adjournment

**Motion** to adjourn at 8:22pm by Selectman Olsen. Seconded by Selectman Bruno.

**Unanimously approved.**

*Respectfully submitted,*

*Susan L Look  
Town Clerk*